

[4.49]

EE 4.49 FACTS and Power Electronics

Answer each part on separate answer book

Questions:

Part A

1.

- (a) Explain why it is expected that the switching frequency of a high power inverter is less than that of a lower power converter. [5]
- (b) Explain how two 6-pulse converters can be combined to give a 12-pulse converter with some harmonic terms removed from the spectrum. [7]
- (c) Figure 1 shows three types of multi-level converter. Discuss the relative merits of the three designs. [8]

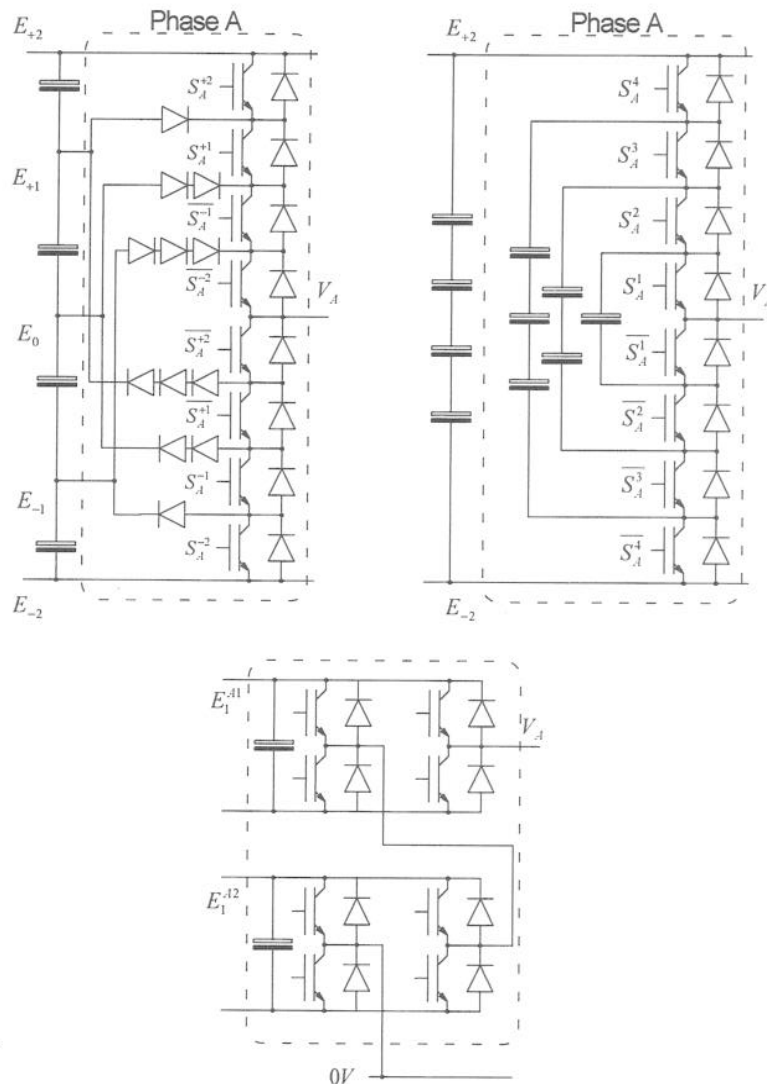

Figure Q1 Three type of multi-level converter

2.

- (a) Draw the characteristic I/V curves of an IGBT using a regular surface gate structure and compare them with the characteristic curves of an IGBT that uses a trench gate structure. Highlight and label the different regions of operation. Use these plots to explain the reasons why a trench gate structure is preferred over a surface gate in high voltage IGBT devices. [8]

- (b) You are required to design a suitable semiconductor valve for use in a FACTS device that will be placed in the medium voltage (33 kV) distribution system. The valve must be able to block the entire 33 kV and be able to conduct 1000 A when turned on. You should use the following semiconductor device:

ABB 5500 V, 1200 A thyristor

The ABB datasheet specifies that the leakage current at breakdown can vary between 100 nA and 400 nA due to manufacturing tolerances.

- (i) What is the minimum number of thyristors needed to make the valve? State whether they should be connected in parallel or series. [3]
- (ii) Design the required passive network (values and topology) to ensure reliable operation of the valve in steady state. [5]
- (c) A FACTS device is designed to operate at 11 kV and 500 A. The total conduction losses in the semiconductors in the converter are 200 kW. Explain the likely total conduction losses in the converter if the same topology of converter is suitably scaled for use on the 33 kV system but rated at only 200 A. [4]

3.

- (a) For each of the signals u_1 , u_2 and u_3 , state whether they contain positive, negative or zero sequence components. Describe the expected form of transformed signals when the matrices T and T_R are applied. [6]

$$u_1 = \begin{bmatrix} U_1 \cos(\omega t + \frac{\pi}{4}) \\ U_1 \cos(\omega t - \frac{2\pi}{3} + \frac{\pi}{4}) \\ U_1 \cos(\omega t + \frac{2\pi}{3} + \frac{\pi}{4}) \end{bmatrix}$$

$$u_2 = \begin{bmatrix} U_0 + U_2 \cos(\omega t) \\ U_0 + U_2 \cos(\omega t - \frac{2\pi}{3}) \\ U_0 + U_2 \cos(\omega t + \frac{2\pi}{3}) \end{bmatrix}$$

$$u_3 = \begin{bmatrix} U_1 \cos(\omega t) \\ U_1 \cos(\omega t + \frac{2\pi}{3}) \\ U_1 \cos(\omega t - \frac{2\pi}{3}) \end{bmatrix}$$

$$T_R = \begin{bmatrix} \cos(\omega t) & \sin(\omega t) & 0 \\ -\sin(\omega t) & \cos(\omega t) & 0 \\ 0 & 0 & 1 \end{bmatrix}$$

- (b) The circuit in figure 3Q is an equivalent circuit of an auto-transformer. [4]
 (i) Consider that the input voltages v_{Iabc} and output currents i_{Oabc} are imposed on the circuit and write the circuit equations in matrix form. [5]
 (ii) Transform the equations to $dq\gamma$ form. [5]
 (iii) Sketch the circuit of the transformed system. [5]

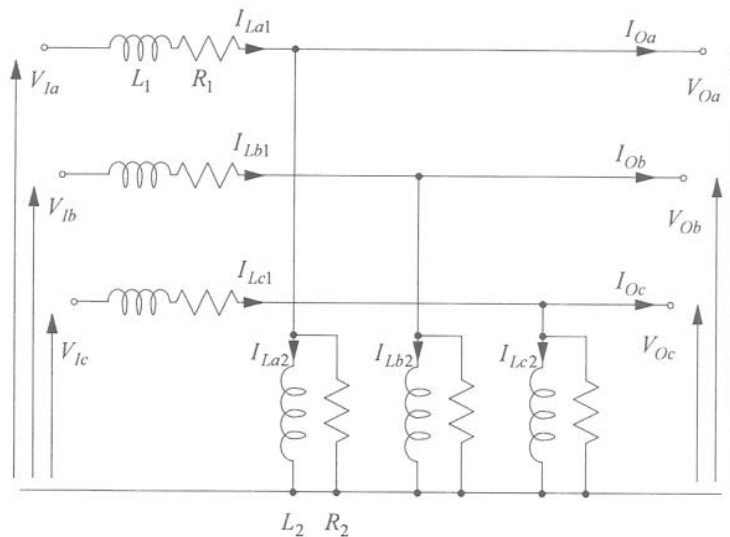

Figure Q3

Part B

4

- (a) How is phase angle regulated in power system? With the help of basic circuit representation of a simple system and power angle plot, show the effectiveness of phase angle regulation in improving power transfer capacity of line [7]
- (b) Discuss modular operating strategy of Thyristor switched capacitor and Thyristor control reactor (TSC+TCR) and its effectiveness in reducing over all capacity of VAR sources. [7]
- (c) Sketch the loss versus loading characteristic for fixed capacitor and Thyristor control reactor (FC+TCR) type Static VAR Compensator (SVC). How does the loss characteristic of the SVC influence the network functions supported by it? [6]

5

- (a) What is meant by the loadability of an AC power transmission line? With the help of a loadability curve of an uncompensated transmission line, explain various factors that affect transmission system loadability. [8]
- (b) Figure Q5 shows a simple model of an interconnected power system. The voltage at the two ends are $V_s \angle \delta$ and $V_r \angle 0$ p.u. The line is modelled by a series inductance and expressed as X_L p.u.. The line transfers power with about 29% capacity margin.
- (i) Find an expression of real power flow across the line as a function of voltage magnitudes, angle difference of two voltages and the reactance of the line. [5]
- (ii) If the line is to be compensated with a capacitor $X_c = kX_L$, what degree of compensation k is needed to improve this margin to 40% for the same level of MW transfer? [7]

Useful hints: capacity margin: $\left(\frac{P_{max}-P}{P_{max}}\right) \cdot 100\%$; P_{max} : maximum real power that can be transferred

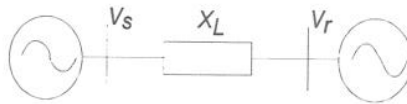

Fig Q5: A simple interconnected power system model

- 6.
- (a) What is loop flow in a meshed system? What consequence does it have on operational efficiency of the network? [4]
 - (b) What are the structural and functional differences between a static VAR compensator (SVC) and a static synchronous compensator (STATCOM)? [5]
 - (c) Discuss how the control slope, either in STATCOM or SVC, can be altered to provide effective voltage regulation. [6]
 - (d) Discuss various technical benefits of the FACTS controllers. [5]