

Special instructions for invigilators: This is a Closed Book examination.

Information for candidates: This is a Closed Book examination.

The Questions

1. The photograph in Figure 1.1 is of a MMIC.
 - a) Draw the equivalent circuit model for the MMIC shown in Figure 1.1, and mark the RF and DC bias ports with the corresponding probe pad numbers shown. Describe the type of amplifier circuit. Hint: if you are uncertain about a component then state any assumptions used. [10]
 - b) Briefly describe the different range of component technologies used for the transistors, inductors and capacitors, and also state the advantages and disadvantages of these technologies. State what compromises have to be made with the design of MMICs, when compared to HMICs. [5]
 - c) Briefly comment as to why the complexity of the full equivalent circuit model is much more than the circuit derived in 1(a) and explain why circuit modelling alone is not sufficient if a significant reduction in the chip area is required. [5]

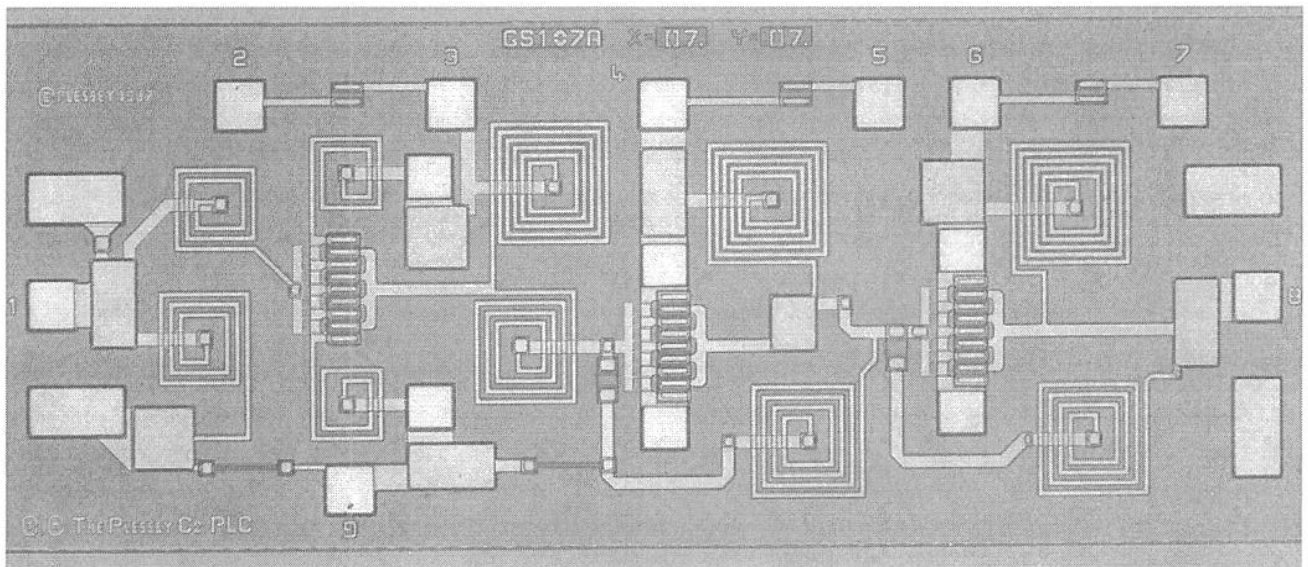

Figure 1.1 Photograph of a $3.5 \times 1.5 \text{ mm}^2$ LNA

2.

- a) With the use of simple illustrations for the attenuation against frequency curves, describe the differences between Butterworth, Chebyshev and Elliptical-function filters. Also, comment on the group delay characteristics for these filters.

[5]

- b) Given prototype low-pass filter attenuation curves and tables for the corresponding normalised element values (see attached sheets), design an L-C lumped-element band-pass filter that meets the following specifications:

Centre Frequency, f_0	500 MHz
3 dB Bandwidth, B	50 MHz
Attenuation Bandwidth	100 MHz
Pass-Band Ripple (Peak-to-Peak)	0.1 dB
Stop-Band Attenuation	45 dB
Input Impedance, R_{IN}	100 Ω
Output Impedance, R_{OUT}	50 Ω .

[15]

Butterworth Low-Pass
Prototype Element Values

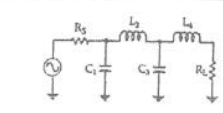

n	R_g/R_L	C_1	L_2	C_3	L_4
2	1.111	1.035	1.835		
	1.250	0.849	2.121		
	1.429	0.697	2.439		
	1.667	0.566	2.828		
	2.000	0.448	3.348		
	2.500	0.342	4.095		
	3.333	0.245	5.313		
	5.000	0.156	7.707		
	10.000	0.074	14.814		
	∞	1.414	0.707		
3	0.800	0.898	1.833	1.599	
	0.800	0.844	1.384	1.026	
	0.700	0.815	1.185	0.777	
	0.600	1.023	0.965	2.702	
	0.500	1.181	0.779	3.981	
	0.400	1.425	0.604	4.064	
	0.300	1.838	0.440	5.383	
	0.200	2.699	0.284	7.910	
	0.100	5.167	0.133	15.455	
	∞	1.500	1.333	0.500	
4	1.111	0.486	1.922	1.744	1.489
	1.250	0.389	1.985	1.511	1.811
	1.429	0.325	1.862	1.291	2.175
	1.667	0.269	2.103	1.062	2.613
	2.000	0.218	2.452	0.883	3.187
	2.500	0.169	3.886	0.691	4.009
	3.333	0.124	3.883	0.507	5.338
	5.000	0.080	5.884	0.331	7.940
	10.000	0.039	11.094	0.182	15.942
	∞	1.631	1.577	1.082	0.383
n	R_L/R_g	L_1	C_2	L_3	C_4

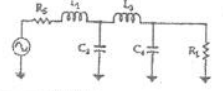

Butterworth Low-Pass Prototype Element Values

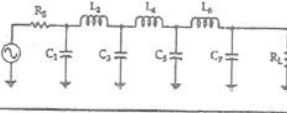

n	R_g/R_L	C_1	L_2	C_3	L_4	C_5	L_6	C_7
5	0.900	0.442	1.027	1.010	1.759	1.389		
	0.800	0.470	0.586	2.061	1.544	1.738		
	0.700	0.517	0.731	2.285	1.333	2.108		
	0.600	0.588	0.609	2.600	1.126	2.552		
	0.500	0.688	0.496	3.051	0.824	3.133		
	0.400	0.838	0.388	3.736	0.727	3.965		
	0.300	1.094	0.285	4.684	0.537	5.307		
	0.200	1.608	0.186	7.185	0.382	7.935		
	0.100	3.512	0.091	14.085	0.173	15.710		
	∞	1.545	1.894	1.382	0.894	0.399		
6	1.111	0.289	1.040	1.322	2.054	1.744	1.335	
	1.250	0.245	1.118	1.158	2.339	1.550	1.659	
	1.429	0.207	1.238	0.957	2.499	1.348	2.022	
	1.667	0.179	1.407	0.801	2.858	1.143	2.500	
	2.000	0.141	1.653	0.654	3.369	0.942	3.094	
	2.500	0.111	2.028	0.514	4.141	0.745	3.931	
	3.333	0.083	2.656	0.379	5.433	0.552	5.280	
	5.000	0.054	3.917	0.248	8.020	0.363	7.922	
	10.000	0.026	7.705	0.132	15.768	0.179	15.738	
	∞	1.553	1.759	1.553	1.302	0.768	0.299	
7	0.800	0.299	0.711	1.494	1.489	2.155	1.727	1.998
	0.800	0.282	0.666	1.517	1.278	2.334	1.546	1.652
	0.700	0.257	0.515	1.688	1.091	2.618	1.350	2.022
	0.600	0.408	0.432	1.928	0.917	3.005	1.150	2.477
	0.500	0.480	0.354	2.273	0.751	3.533	0.951	3.064
	0.400	0.590	0.278	2.795	0.592	4.380	0.754	3.904
	0.300	0.775	0.206	3.671	0.437	5.761	0.560	5.258
	0.200	1.145	0.135	5.427	0.287	8.526	0.369	7.908
	0.100	2.257	0.067	10.700	0.142	16.822	0.182	15.748
	∞	1.558	1.799	1.659	1.397	1.055	0.656	0.223
n	R_L/R_g	L_1	C_2	L_3	C_4	L_5	C_6	L_7

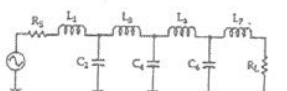

Chebyshev Low-Pass Element Values
for 0.01-dB Ripple

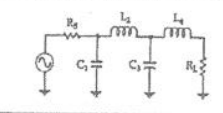

n	R_g/R_L	C_1	L_2	C_3	L_4
2	1.101	1.347	1.483		
	1.111	1.547	1.585		
	1.250	0.943	1.997		
	1.429	0.759	2.344		
	1.667	0.600	2.750		
	2.000	0.479	3.277		
	2.500	0.363	4.033		
	3.333	0.259	5.255		
	5.000	0.164	7.950		
	10.000	0.078	14.749		
∞	1.413	0.742			
3	1.000	1.181	1.821	1.181	
	0.900	1.062	1.660	1.480	
	0.800	1.097	1.443	1.806	
	0.700	1.180	1.228	2.185	
	0.600	1.274	1.024	2.598	
	0.500	1.452	0.829	3.194	
	0.400	1.734	0.645	3.974	
	0.300	2.216	0.470	5.220	
	0.200	3.193	0.305	7.834	
	0.100	8.141	0.146	15.300	
∞	1.501	1.433	0.591		
4	1.100	0.850	1.938	1.791	1.046
	1.111	0.854	1.946	1.744	1.185
	1.250	0.818	2.075	1.542	1.617
	1.429	0.455	2.279	1.334	2.008
	1.667	0.308	2.571	1.128	2.481
	2.000	0.216	2.994	0.929	3.045
	2.500	0.242	3.641	0.729	3.875
	3.333	0.174	4.727	0.538	5.209
	5.000	0.112	6.910	0.353	7.813
	10.000	0.054	13.469	0.173	15.510
∞	1.520	1.694	1.512	0.523	
n	R_L/R_g	L_1	C_2	L_3	C_4

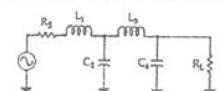

Chebyshev Low-Pass Element Values for 0.01-dB Ripple

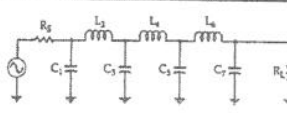

n	R_g/R_L	C_1	L_2	C_3	L_4	C_5	L_6	C_7
5	1.000	0.977	1.685	2.037	1.685			
	0.900	0.880	1.456	2.174	1.641			
	0.800	0.877	1.235	2.379	1.499			
	0.700	0.929	1.040	2.658	1.323			
	0.600	1.019	0.863	3.041	1.135			
	0.500	1.168	0.699	3.534	0.942			
	0.400	1.398	0.544	4.403	0.749			
	0.300	1.797	0.398	5.772	0.557			
	0.200	2.604	0.259	8.514	0.368			
	0.100	5.041	0.127	16.741	0.182			
∞	1.547	1.795	1.645	1.237	0.488			
6	1.101	0.851	1.796	1.841	2.027	1.631		0.937
	1.111	0.780	1.782	1.775	2.094	1.638		1.053
	1.250	0.545	1.894	1.489	2.403	1.507		1.504
	1.429	0.436	2.038	1.266	2.735	1.332		1.899
	1.667	0.351	2.238	1.061	3.187	1.145		2.357
	2.000	0.279	2.876	0.867	3.769	0.954		2.948
	2.500	0.214	3.261	0.682	4.867	0.761		3.790
	3.333	0.155	4.245	0.503	6.163	0.598		5.143
	5.000	0.100	6.223	0.330	9.151	0.376		7.785
	10.000	0.048	12.171	0.162	18.105	0.187		15.285
∞	1.551	1.847	1.790	1.598	1.190	0.469		
7	1.000	0.913	1.595	2.002	1.870	2.002		0.913
	0.900	0.818	1.362	2.080	1.722	2.202		1.206
	0.800	0.811	1.150	2.262	1.595	2.405		1.538
	0.700	0.857	0.967	2.516	1.323	2.802		1.910
	0.600	0.943	0.803	2.872	1.061	3.250		2.359
	0.500	1.080	0.650	3.382	0.867	3.875		2.948
	0.400	1.297	0.507	4.156	0.735	4.812		3.790
	0.300	1.689	0.372	5.454	0.546	6.370		5.148
	0.200	2.242	0.242	8.057	0.360	9.484		7.802
	0.100	4.701	0.119	15.872	0.178	18.818		15.652
∞	1.559	1.867	1.866	1.765	1.563	1.161	0.456	
n	R_L/R_g	L_1	C_2	L_3	C_4	L_5	C_6	L_7

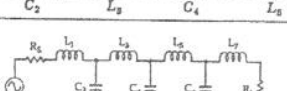

Chebyshev Low-Pass Prototype Element Values for 0.1-dB Ripple

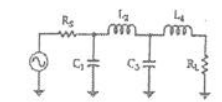

n	R_0/R_L	C_1	L_2	C_3	L_4	
2	1.355	1.209	1.838			
	1.429	0.977	1.882			
	1.667	0.733	2.489			
	2.000	0.590	3.054			
	2.500	0.417	3.827			
	3.333	0.293	5.050			
	5.000	0.184	7.426			
	10.000	0.087	14.433			
	∞	1.391	0.819			
	∞	1.433	1.594	1.433		
3	1.000	1.433	1.594	1.433		
	0.900	1.426	1.494	1.622		
	0.800	1.451	1.356	1.671		
	0.700	1.521	1.182	2.180		
	0.600	1.648	1.017	2.903		
	0.500	1.853	0.838	3.159		
	0.400	2.186	0.660	3.968		
	0.300	2.783	0.486	5.279		
	0.200	3.942	0.317	7.850		
	0.100	7.512	0.155	15.466		
∞	1.513	1.510	0.718			
4	1.035	0.932	2.148	1.585	1.341	
	1.439	0.779	2.348	1.429	1.700	
	1.967	0.576	2.730	1.185	2.243	
	2.600	0.440	3.227	0.967	3.556	
	2.800	0.329	3.961	0.760	3.898	
	3.333	0.233	5.178	0.560	5.030	
	5.000	0.148	7.607	0.367	7.614	
	10.000	0.070	14.827	0.180	15.230	
	∞	1.511	1.768	1.455	0.873	

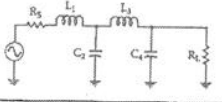

Chebyshev Low-Pass Prototype Element Values for 0.1-dB Ripple

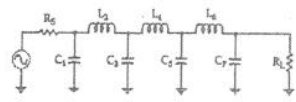

n	R_0/R_L	C_1	L_2	C_3	L_4	C_5	L_6	C_7	
5	1.000	1.301	1.555	2.241	1.555	1.301			
	0.900	1.285	1.433	2.280	1.458	1.488			
	0.800	1.300	1.282	2.582	1.382	1.738			
	0.700	1.358	1.117	2.888	1.244	2.062			
	0.600	1.470	0.947	3.268	1.085	2.464			
	0.500	1.654	0.778	3.845	0.913	3.085			
	0.400	1.954	0.612	4.720	0.733	3.886			
	0.300	2.477	0.451	6.196	0.530	5.237			
	0.200	3.546	0.295	9.127	0.366	7.289			
	0.100	6.787	0.115	17.957	0.182	15.745			
∞	1.581	1.807	1.786	1.417	0.651				
6	1.355	0.942	2.080	1.659	2.247	1.534	1.877		
	1.429	0.735	2.249	1.454	2.544	1.405	1.629		
	1.667	0.542	2.600	1.183	3.064	1.185	2.174		
	2.000	0.414	3.068	0.958	3.712	0.979	2.794		
	2.500	0.310	3.785	0.749	4.651	0.778	3.845		
	3.333	0.229	4.927	0.551	6.185	0.550	4.896		
	5.000	0.139	7.250	0.361	9.261	0.364	7.618		
	10.000	0.067	14.230	0.179	18.497	0.180	15.350		
	∞	1.534	1.894	1.831	1.749	1.094	0.638		
	7	1.000	1.282	1.520	2.239	1.680	2.239	1.820	1.963
0.900		1.242	1.395	2.361	1.578	2.397	1.459	1.447	
0.800		1.255	1.245	2.545	1.443	2.824	1.362	1.697	
0.700		1.310	1.083	2.819	1.283	2.942	1.233	2.021	
0.600		1.417	0.917	3.205	1.039	3.394	1.081	2.444	
0.500		1.595	0.753	3.764	0.828	4.015	0.814	3.018	
0.400		1.885	0.593	4.618	0.742	4.970	0.738	3.835	
0.300		2.392	0.437	6.054	0.556	6.569	0.527	5.217	
0.200		3.428	0.286	8.937	0.369	9.770	0.372	7.890	
0.100		6.570	0.141	17.603	0.184	19.370	0.186	15.813	
∞	1.575	1.859	1.891	1.827	1.734	1.370	0.631		

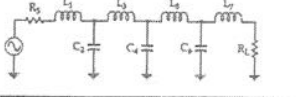

Chebyshev Low-Pass Prototype Element Values for 0.5-dB Ripple

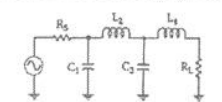

n	R_0/R_L	C_1	L_2	C_3	L_4	
2	1.984	0.983	1.950			
	2.000	0.909	2.103			
	2.500	0.594	3.185			
	3.333	0.375	4.411			
	5.000	0.228	6.700			
	10.000	0.105	13.322			
	∞	1.307	0.975			
	3	1.000	1.864	1.280	1.834	
		0.900	1.918	1.209	2.026	
		0.800	1.997	1.120	2.237	
0.700		2.114	1.015	2.517		
0.500		2.957	0.759	3.436		
0.400		2.985	0.615	4.342		
0.300		3.729	0.463	5.576		
0.200		5.254	0.309	8.225		
0.100		9.890	0.153	16.118		
∞		1.572	1.518	0.932		
4	1.984	0.920	2.586	1.304	1.820	
	2.000	0.845	2.720	1.238	1.985	
	2.500	0.516	3.766	0.869	3.121	
	3.333	0.344	5.120	0.621	4.480	
	5.000	0.210	7.708	0.400	6.887	
	10.000	0.098	15.352	0.194	14.202	
	∞	1.436	1.889	1.521	0.913	

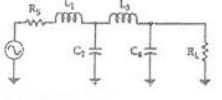

Chebyshev Low-Pass Prototype Element Values for 0.5-dB Ripple

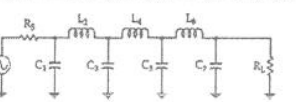

n	R_0/R_L	C_1	L_2	C_3	L_4	C_5	L_6	C_7	
5	1.000	1.807	1.303	2.091	1.303	1.807			
	0.900	1.854	1.222	2.840	1.238	1.970			
	0.800	1.928	1.120	3.060	1.157	2.185			
	0.700	2.035	1.015	3.353	1.036	2.470			
	0.600	2.290	0.860	3.785	0.942	2.861			
	0.500	2.457	0.754	4.267	0.810	3.414			
	0.400	2.870	0.609	5.290	0.664	4.243			
	0.300	3.588	0.459	6.871	0.508	5.625			
	0.200	5.064	0.306	10.054	0.343	8.367			
	0.100	9.556	0.153	19.647	0.173	16.574			
∞	1.630	1.740	1.922	1.514	0.903				
6	1.984	0.905	2.577	1.366	2.713	1.299	1.796		
	2.000	0.830	2.704	1.291	2.872	1.237	1.956		
	2.500	0.536	3.722	0.890	4.109	0.881	3.103		
	3.333	0.337	5.055	0.632	5.699	0.635	4.481		
	5.000	0.206	7.615	0.400	8.732	0.412	7.031		
	10.000	0.096	15.188	0.197	17.681	0.202	14.433		
	7	1.000	1.790	1.296	2.718	1.385	2.718	1.896	1.700
		0.900	1.835	1.215	2.889	1.308	2.883	1.234	1.953
		0.800	1.906	1.118	3.070	1.215	3.107	1.155	2.168
		0.700	2.011	1.007	3.284	1.105	3.416	1.058	2.455
0.600		2.174	0.882	3.772	0.979	3.852	0.944	2.848	
0.500		2.458	0.747	4.370	0.838	4.289	0.814	3.405	
0.400		2.835	0.604	5.295	0.682	5.470	0.669	4.243	
0.300		3.546	0.455	6.867	0.522	7.134	0.513	5.635	
0.200		5.007	0.303	10.049	0.352	10.498	0.348	8.404	
0.100		9.458	0.151	19.649	0.178	20.631	0.176	16.665	
∞	1.646	1.777	2.031	1.789	1.924	1.503	0.895		

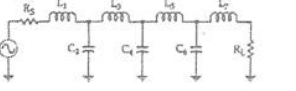

3.

- a) With the aid of a diagram, describe the S-parameter representation of a linear two-port circuit, stating the precise definitions of all parameters and the main power specifications.

[5]

- b) State which RF components best described the following S-parameter matrices and calculate any relevant power specifications:

$$(i) \quad [S] = \begin{pmatrix} 0 & e^{-j720} \\ e^{-j720} & 0 \end{pmatrix} \quad (3.1)$$

$$(ii) \quad [S] = \begin{pmatrix} 0 & 0.07e^{-j30} \\ e^{-j60} & 0 \end{pmatrix} \quad (3.2)$$

$$(iii) \quad [S] = \begin{pmatrix} 0.1e^{-j30} & 0.3e^{-j80} \\ 9.7e^{-j80} & 0.15e^{-j60} \end{pmatrix} \quad (3.3)$$

[5]

- c) Derive an algebraic expression for the overall Γ_{in} , of a linear two-port network that is terminated at its output port with a one-port network represented by Γ_L .

[6]

- d) Referring to the result in 3(c), state the condition for stability for the overall one-port network, for any value of generator source impedance. If the two-port network in 3(b)(ii) is terminated with a load impedance having $\Gamma_L = 0.5$, determine if the overall one-port network is stable.

[4]

4. An amplifier chain is illustrated in Figure 4.1. All sub-systems are assumed to be perfectly impedance matched.

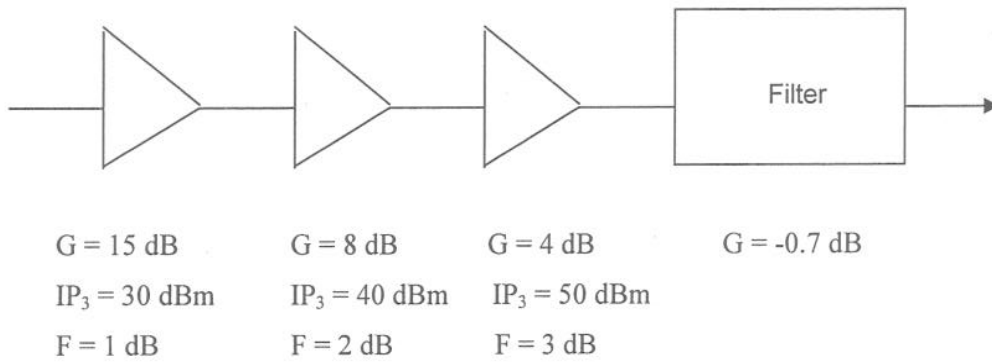

Figure 4.1 Amplifier Chain

For an overall input power of 3 dBm, calculate the following at the output of each sub-system, while also stating the main equations used:-

- | | |
|---------------|-----|
| (i) C | [2] |
| (ii) IP_3 | [6] |
| (iii) IMD_3 | [3] |
| (iv) I_3 | [3] |
| (v) Overall F | [6] |

All variables have their usual meaning.

5.

- a) Explain why filters having sharp frequency roll-off characteristics require large components to achieve low insertion losses. [4]
- b) Explain why impedance and admittance inverters are required for realising practical narrow bandwidth filters. In addition, with the use of simple block diagrams, explain how these inverters work. [6]
- c) Redesign the 1.8 GHz resonator topology shown in Figure 5.1, by employing all capacitive admittance inverters, so that the series tuned circuit can be replaced with a shunt parallel tuned circuit.

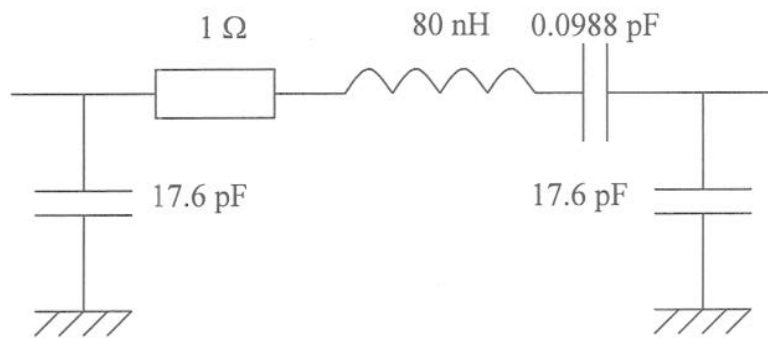

Figure 5.1

- d) What effect on the insertion phase does the all capacitance admittance inverter have? [2]

6.

a) Draw the topology of a double-balanced amplifier. If 3 dB quadrature couplers are used in conjunction with identical non-ideal single-ended amplifiers, use S-parameter analysis to determine expressions for the overall insertion gain and input return loss. Assume the couplers are perfectly matched to the reference impedance, Z_0 , and the interconnections between the main components are ideal.

[10]

b) For the topology in 6(a), if the working single-ended amplifiers have a forward voltage wave transmission coefficient of $S_{21} = |10|\angle 35^\circ$, determine the overall insertion gain and input return loss if one of the amplifiers fails, such that $S_{21} = 0$. Assume that there is no change in the input or output impedances of the failed transistor. What is the main application of this topology and what are its advantages and disadvantages when compared to a single-ended amplifier?

[10]