

E4.03 / Inc 4.3 /

S010

1
16

Mobile Radio Communications

2007-2008

SOLUTIONS

Problem 1. a

$$P_r = P_t \left[\frac{\sqrt{G_t} \lambda}{4\pi d} \right]^2 \quad \lambda = c/f_c = 0.06$$

$$10^{-3} = P_t \left[\frac{\lambda}{4\pi 10} \right]^2 \Rightarrow P_t = 4.39 \text{KW}$$

$$10^{-3} = P_t \left[\frac{\lambda}{4\pi 100} \right]^2 \Rightarrow P_t = 438.65 \text{KW}$$

Problem 1.b

$$P_{noise} = -160 \text{dBm}$$

$$f_c = 1 \text{GHz}, d_0 = 1 \text{m}, K = (\lambda/4\pi d_0)^2 = 5.7 \times 10^{-4}, \lambda = 0.3, \gamma = 4$$

$$\text{We want } SNR_{recd} = 20 \text{dB} = 100$$

$$\therefore \text{Noise power is } 10^{-19}$$

$$P = P_t K \left(\frac{d_0}{d} \right)^\gamma$$

$$10^{-17} = 10K \left(\frac{0.3}{d} \right)^4$$

$$d \leq 260.7 \text{m}$$

Problem 1.c

$$P_r = P_t - P_L(d) - \sum_i^3 FAF_i - \sum_j^2 PAF_j$$

$$FAF = (5, 10, 6), \quad PAF = (3.4, 3.4)$$

$$P_L(d) K \left(\frac{d_0}{d} \right)^\gamma = 10^{-8} = -8 \text{dB}$$

$$-110 = P_t - 80 - 5 - 10 - 6 - 3.4 - 3.4$$

$$\Rightarrow P_t = -2.2 \text{dBm}$$

Problem 1.d
Path loss parameters

$$f_c = 900 \text{ MHz}$$

$$\lambda = \frac{1}{3} \text{ m}$$

$$\sigma_{\psi_{dB}} = 6 \text{ dB}$$

$$SNR_{Req} = 15 \text{ dB}$$

$$P_t = 1 \text{ W}$$

$$G_l = 3 \text{ dB}$$

$$P_{noise} = -40 \text{ dBm}$$

$$P_{received} = -55 \text{ dB}$$

Suppose we choose a cell of radius d

$$\mu(d) = P_{received}(\text{due to path loss alone})$$

$$= \left(\frac{\sqrt{2} \times \frac{1}{3}}{4\pi d} \right)^2 = \frac{0.0014}{d^2}$$

$$\mu_{dB}(d) = 10 \log_{10}(\mu(d))$$

Probability of success

$$p(P_{received}(d) > -55) = 0.9$$

$$P\left(\frac{P_{received}(d) - \mu_{dB}}{\sigma_{\psi_{dB}}} > \frac{-55 - \mu_{dB}}{\sigma_{\psi_{dB}}}\right) = 0.9$$

Probability of success

$$Q\left(\frac{-55 - \mu_{dB}}{\sigma_{\psi_{dB}}}\right) = 0.9$$

$$0.5 \times \text{erfc}\left(\frac{-55 - \mu_{dB}}{2 \times \sigma_{\psi_{dB}}}\right) = 0.9$$

$$0.5 \times \text{erfc}\left(\frac{-55 - \mu_{dB}}{\sqrt{2} \times 6}\right) = 0.9$$

Argument of the erfc is

$$\frac{-55 - \mu_{dB}}{\sqrt{2} \times 6} = -1.282$$

mean signal power measured in dB

$$\mu_{dB} = -47.308 \text{ dB}$$

Mean signal power

$$\mu(d) = \frac{0.0014}{d^2} = 1.86 \times 10^{-5}$$

Cell radius

$$d = 8.68 \text{ m}$$

Problem 2.a

For the 2 ray model:

$$\tau_0 = \frac{l}{c}$$

$$\tau_1 = \frac{x + x'}{c}$$

$$\therefore \text{delay spread}(T_m) = \frac{x + x' - l}{c} = \frac{\sqrt{(h_t + h_r)^2 + d^2} - \sqrt{(h_t - h_r)^2 + d^2}}{c}$$

when $d \gg (h_t + h_r)$

$$T_m = \frac{1}{c} \frac{2h_t h_r}{d}$$

$$h_t = 10m, \quad h_r = 4m, \quad d = 100m$$

$$\therefore T_m = 2.67 \times 10^{-9} s$$

Problem 2.b

$$d = vt$$

$$r + r' = d + \frac{2h^2}{d}$$

Equivalent low-pass channel impulse response is given by

$$c(\tau, t) = \alpha_0(t)e^{-j\phi_0(t)}\delta(\tau - \tau_0(t)) + \alpha_1(t)e^{-j\phi_1(t)}\delta(\tau - \tau_1(t))$$

$$\alpha_0(t) = \frac{\lambda\sqrt{G_l}}{4\pi d} \text{ with } d = vt$$

$$\phi_0(t) = 2\pi f_c \tau_0(t) - \phi_{D_0}$$

$$\tau_0(t) = d/c$$

$$\phi_{D_0} = \int_t 2\pi f_{D_0}(t) dt$$

$$f_{D_0}(t) = \frac{v}{\lambda} \cos \theta_0(t)$$

$$\theta_0(t) = 0 \quad \forall t$$

$$\alpha_1(t) = \frac{\lambda R \sqrt{G_l}}{4\pi(r+r')} = \frac{\lambda R \sqrt{G_l}}{4\pi(d + \frac{2h^2}{d})} \text{ with } d = vt$$

$$\phi_1(t) = 2\pi f_c \tau_1(t) - \phi_{D_1}$$

$$\tau_1(t) = (r + r')/c = (d + \frac{2h^2}{d})/c$$

$$\phi_{D_1} = \int_t 2\pi f_{D_1}(t) dt$$

$$f_{D_1}(t) = \frac{v}{\lambda} \cos \theta_1(t)$$

$$\theta_1(t) = \pi - \arctan \frac{h}{d/2} \quad \forall t$$

Problem 2.c

Delay for LOS component = $\tau_0 = 23$ ns

Delay for First Multipath component = $\tau_1 = 48$ ns

Delay for Second Multipath component = $\tau_2 = 67$ ns

τ_c = Delay for the multipath component to which the demodulator synchronizes.

$$T_m = \max_m \tau_m - \tau_c$$

So, when $\tau_c = \tau_0$, $T_m = 44$ ns. When $\tau_c = \tau_1$, $T_m = 19$ ns.

Problem 2.d

Use CDF strategy.

$$F_z(z) = P[x^2 + y^2 \leq z^2] = \int_{x^2 + y^2 \leq z^2} \frac{1}{2\pi\sigma^2} e^{-\frac{(x^2 + y^2)}{2\sigma^2}} dx dy = \int_0^{2\pi} \int_0^z \frac{1}{2\pi\sigma^2} e^{-\frac{r^2}{2\sigma^2}} r dr d\theta = 1 - e^{-\frac{z^2}{2\sigma^2}} \quad (z \geq 0)$$

$$\frac{df_z(z)}{dz} = \frac{z}{\sigma^2} e^{-\frac{z^2}{2\sigma^2}} \rightarrow \text{Rayleigh}$$

For Power:

$$F_{z^2}(z) = P[Z \leq \sqrt{z}] = 1 - e^{-\frac{z}{2\sigma^2}}$$

$$f_z(z) = \frac{1}{2\sigma^2} e^{-\frac{z}{2\sigma^2}} \rightarrow \text{Exponential}$$

Problem 2.e.i

In a wireless medium, due to reflection, scattering, diffraction and refraction, a signal usually reaches a destination through multiple paths of various distances. Thus, a receiver, instead of getting a copy of the signal, often obtains replicas of a signal which arrive at different times. The superposition of the delayed replicas results in the broadening of the signal. This is known as time dispersion, which corresponds to a non-flat frequency response of the channel. For relatively large signal bandwidth, one encounters frequency-selective fading, with different frequency components of the signal being handled differently over the channel, leading to signal distortion. For the case of digital signals, this distortion introduced by frequency-selective fading manifests itself in intersymbol interference (ISI), with successive digital symbols overlapping into adjacent symbol intervals.

Problem 2.e.i

For IS-95 and cdma2000, multipath echoes appearing much greater than $1/(2\pi \times 1.25)\mu\text{sec} \approx 0.13\mu\text{sec}$ apart will be resolvable. Therefore, multipath rays should be resolvable for delay spreads of $1\mu\text{sec}$ and $6\mu\text{sec}$, but probably not for the delay spread of $0.5\mu\text{sec}$.

For WCDMA, multipath echoes appearing much greater than $1/(2\pi \times 5)\mu\text{sec} \approx 0.032\mu\text{sec}$ apart will be resolvable, which is valid for all the three cases of delay spread.

Problem 3.a

(a) Maximize capacity given by

$$C = \max_{S(\gamma): \int S(\gamma)p(\gamma)d\gamma = \bar{S}} \int_{\gamma} B \log \left(1 + \frac{S(\gamma)\gamma}{\bar{S}} \right) p(\gamma) d\gamma.$$

Construct the Lagrangian function

$$\mathcal{L} = \int_{\gamma} B \log \left(1 + \frac{S(\gamma)\gamma}{\bar{S}} \right) p(\gamma) d\gamma - \lambda \int \frac{S(\gamma)}{\bar{S}} p(\gamma) d\gamma$$

Taking derivative with respect to $S(\gamma)$, (refer to discussion section notes) and setting it to zero, we obtain,

$$\frac{S(\gamma)}{\bar{S}} = \begin{cases} \frac{1}{\gamma_0} - \frac{1}{\gamma} & \gamma \geq \gamma_0 \\ 0 & \gamma < \gamma_0 \end{cases}$$

Now, the threshold value must satisfy

$$\int_{\gamma_0}^{\infty} \left(\frac{1}{\gamma_0} - \frac{1}{\gamma} \right) p(\gamma) d\gamma = 1$$

Evaluating this with $p(\gamma) = \frac{1}{10}e^{-\gamma/10}$, we have

$$1 = \frac{1}{10\gamma_0} \int_{\gamma_0}^{\infty} e^{-\gamma/10} d\gamma - \frac{1}{10} \int_{\gamma_0}^{\infty} \frac{e^{-\gamma/10}}{\gamma} d\gamma \quad (1)$$

$$= \frac{1}{\gamma_0} e^{-\gamma_0/10} - \frac{1}{10} \int_{\gamma_0}^{\infty} \frac{e^{-\gamma}}{\gamma} d\gamma \quad (2)$$

$$= \frac{1}{\gamma_0} e^{-\gamma_0/10} - \frac{1}{10} \text{EXPINT}(\gamma_0/10) \quad (3)$$

where EXPINT is as defined in matlab. This gives $\gamma_0 = 0.7676$. The power adaptation becomes

$$\frac{S(\gamma)}{\bar{S}} = \begin{cases} \frac{1}{0.7676} - \frac{1}{\gamma} & \gamma \geq 0.7676 \\ 0 & \gamma < 0.7676 \end{cases}$$

(b) Capacity can be computed as

$$C/B = \frac{1}{10} \int_{0.7676}^{\infty} \log(\gamma/0.7676) e^{-\gamma/10} d\gamma = 2.0649 \text{ nats/sec/Hz.}$$

Note that I computed all capacities in nats/sec/Hz. This is because I took the natural log. In order to get the capacity values in bits/sec/Hz, the capacity numbers simply need to be divided by natural log of 2.

(c) AWGN capacity $C/B = \log(1 + 10) = 2.3979 \text{ nats/sec/Hz.}$

(d) Capacity when only receiver knows γ

$$C/B = \frac{1}{10} \int_0^{\infty} \log(1 + \gamma) e^{-\gamma/10} d\gamma = 2.0150 \text{ nats/sec/Hz.}$$

(e) Capacity using channel inversion is ZERO because the channel can not be inverted with finite average power. Threshold for outage probability 0.05 is computed as

$$\frac{1}{10} \int_{\gamma_0}^{\infty} e^{-\gamma/10} d\gamma = 0.95$$

which gives $\gamma_0 = 0.5129$. This gives us the capacity with truncated channel inversion as

$$C/B = \log \left[1 + \frac{1}{\frac{1}{10} \int_{\gamma_0}^{\infty} \frac{1}{\gamma} e^{-\gamma/10} d\gamma} \right] * 0.95 \quad (4)$$

$$= \log \left[1 + \frac{1}{\frac{1}{10} \text{EXPINT}(\gamma_0/10)} \right] * 0.95 \quad (5)$$

$$= 1.5463 \text{ nats/s/Hz.} \quad (6)$$

- (f) Channel Mean = -5 dB = 0.3162. So for perfect channel knowledge at transmitter and receiver we compute $\gamma_0 = 0.22765$ which gives capacity $C/B = 0.36$ nats/sec/Hz.
With AWGN, $C/B = \log(1 + 0.3162) = 0.2748$ nats/sec/Hz.
With channel known only to the receiver $C/B = 0.2510$ nats/sec/Hz.

Capacity with AWGN is always greater than or equal to the capacity when only the receiver knows the channel. This can be shown using Jensen's inequality. However the capacity when the transmitter knows the channel as well and can adapt its power, can be higher than AWGN capacity specially at low SNR. At low SNR, the knowledge of fading helps to use the low SNR more efficiently.

Problem 3.b

We show this for the case of a discrete fading distribution

$$C = \sum \log \left(1 + \frac{(1+j)^2 P_j}{N_0 B} \right)$$

$$\mathcal{L} = \sum_i \log \left(1 + \frac{(1+j)^2 P_j}{N_0 B} \right) - d_j \left(\sum_j P_j - P \right)$$

$$\frac{\partial \mathcal{L}}{\partial P_j} = 0$$

$$\Rightarrow \frac{(1+j)^2 P_j}{N_0 B} = \frac{1}{\lambda} \frac{(1+j)^2}{N_0 B} - 1$$

$$\text{let } \gamma_j = \frac{(1+j)^2 P_j}{N_0 B}$$

$$\Rightarrow \frac{P_j}{P} = \frac{1}{\lambda P} - \frac{1}{\gamma_j}$$

$$\text{denote } \frac{1}{\gamma_0} = \frac{1}{\lambda P}$$

$$\therefore \frac{P_j}{P} = \frac{1}{\gamma_0} - \frac{1}{\gamma_j}$$

subject to the constraint

$$\frac{\sum P_j}{P} = 1$$

Problem 4a

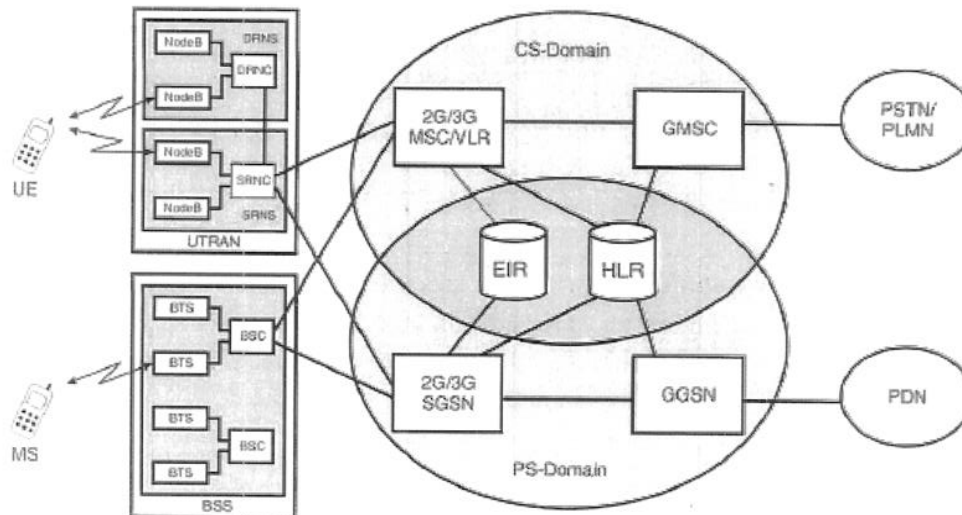
Problem 4.a.i

The GGSN is primarily provisioned by a router, which supports traditional gateway functionality such as publishing subscriber addresses, mapping addresses, routing and tunneling packets, screening messages, and counting packets. Figure 18.4(b) shows a GGSN product. A GGSN may contain DNS functions to map routing area identifiers with serving SGSNs and *Dynamic Host Configuration Protocol* (DHCP) functions to allocate dynamic IP addresses to MSs.

The GGSN maintains an activated PDP context for tunneling the packets of the attached MS to the corresponding SGSN. The information items include (a partial list):

- IMSI.
- PDP type and PDP address.
- Dynamic address indication.
- QoS profile negotiated.
- IP address of the SGSN currently serving this MS.
- Access point name of the external data network.
- Charging ID.
- MNRG flag, which indicates whether the MS is marked as not reachable for GPRS at the HLR.

Note that the GGSN does not need to record subscribed and requested QoS profiles. Both are maintained in the SGSN.

BSS to GGSN, which provides ciphering, mobility management (e.g., inter-SGSN routing area update and inter-PLMN roaming), charging, and statistics collection (i.e., support of billing records). To provide services to a GPRS MS, the SGSN establishes an MM context that contains mobility and security information for the MS. At PDP context activation, the SGSN establishes a PDP context that is used to route data between the MS and the GGSN. SGSN maintains MM/PDP context information when the MS is in one of the two MM states (STANDBY or READY). For an MS, the SGSN MM context includes:

- IMSI, P-TMSI, and mobile station ISDN number (MSISDN).
- MM state.
- Routing area identity and cell identity.
- Address of the VLR currently serving the MS.
- IP address of the new SGSN where the buffered packets should be forwarded.
- Authentication and ciphering parameters.
- Current ciphering key K_c and the selected ciphering algorithm.
- MS radio access capabilities and GPRS network access capabilities.
- MNRG (Mobile Station Not Reachable for GPRS flag) indicating whether activity from the MS should be reported to the HLR.
- NGAF (non-GPRS Alert flag) indicating whether activity from the MS should be reported to the VLR.
- PPF (Paging Proceed flag) indicating whether paging for GPRS and non-GPRS services can be initiated.

Each MM context associates with zero or more of the following PDP contexts (a partial list):

- PDP context identifier, PDP type, PDP address, and PDP state.
- Access point name to the external data network.
- Subscribed, requested, and negotiated QoS profiles.
- IP address of the GGSN currently used by the activated PDP context
- Identifier of the charging records generated by SGSN and GGSN.

Most vendors developed SGSN based on existing multiple processor system products, where the control processors are configured with hot standby redundancy. Lucent's solution supports 40,000 attached users and 4,000 simultaneous active GPRS data sessions. For Nortel's Passport 8380

Problem 4.a.ii

RANAP protocol

RANAP is the signalling protocol in Iu that contains all the control information specified for the Radio Network Layer. The functionality of RANAP is implemented by various RANAP Elementary Procedures (EPs). Each RANAP function may require the execution of one or more EPs. Each EP consists of either just the request message (class 2 EP), the request and response message pair (class 1 EP), or one request message and one or more response messages (class 3 EP). The following RANAP functions are defined:

- *Relocation.* This function handles both SRNS Relocation and Hard Handover, including intersystem case to/from GSM:
- *SRNS rRelocation.* The SRNS functionality is relocated from one RNS to another without changing the radio resources and without interrupting the user data flow. The prerequisite for SRNS relocation is that all Radio Links are already in the same DRNC that is the target for the relocation.
- *Inter-RNS hard handover.* This is used to relocate the serving RNS functionality from one RNS to another and to change the radio resources correspondingly by a hard handover in the Uu interface. The prerequisite for Hard Handover is that the UE is at the border of the source and target cells.
- *RAB management.* This function combines all RAB handling:
 - RAB Setup, including the possibility for queuing the setup;
 - modification of the characteristics of an existing RAB;
- *Iu release.* Releases all resources (Signalling link and U-Plane) from a given instance of Iu related to the specified UE. Also includes the RAN-initiated case.
- *Reporting unsuccessfully transmitted data.* This function allows the CN to update its charging records with information from UTRAN if part of the data sent was not successfully sent to the UE.
- *Common ID management.* In this function the permanent identification of the UE is sent from the CN to UTRAN to allow paging coordination from possibly two different CN domains.
- *Paging.* This is used by CN to page an idle UE for a UE terminating service request, such as a voice call. A paging message is sent from the CN to UTRAN with the UE common identification (permanent ID) and the paging area. UTRAN will either use an existing signalling connection, if one exists, to send the page to the UE or broadcast the paging in the requested area.
- *Management of tracing.* The CN may, for O&M purposes, request UTRAN to start recording all activity related to a specific UE-UTRAN connection.
- *UE-CN signalling transfer.* This functionality provides transparent transfer of UE-CN signalling messages that are not interpreted by UTRAN in two cases.
 - / ◦ *Transfer of the first UE message from UTRAN to UE:* this may be, for example, a response to paging, a request of a UE-originated call, or just registration to a new area. It also initiates the signalling connection for the Iu.
 - *Direct transfer:* used for carrying all consecutive signalling messages over the Iu signalling connection in both the uplink and downlink directions.

- *Security mode control.* This is used to set the ciphering or integrity checking on or off. When ciphering is on, the signalling and user data connections in the radio interface are encrypted with a secret key algorithm. When integrity checking is on, an integrity checksum, further secured with a secret key, is added to some or all of the radio interface signalling messages. This ensures that the communication partner has not changed, and the content of the information has not been altered.
- *Management of overload.* This is used to control the load over the Iu interface against overload due, for example, to processor overload at the CN or UTRAN. A simple mechanism is applied that allows stepwise reduction of the load and its stepwise resumption, triggered by a timer.
- *Reset.* This is used to reset the CN or the UTRAN side of the Iu interface in error situations. One end of the Iu may indicate to the other end that it is recovering from a restart, and the other end can remove all previously established connections.
- *Location reporting.* This functionality allows the CN to receive information on the location of a given UE. It includes two elementary procedures, one for controlling the location reporting in the RNC and the other to send the actual report to the CN.

Problem 4.bi

Radio Network Controller

The RNC is the network element responsible for the control of the radio resources of UTRAN. It interfaces the CN (normally to one MSC and one SGSN) and also terminates the Radio Resource Control (RRC) protocol that defines the messages and procedures between the mobile and UTRAN. It logically corresponds to the GSM BSC.

In case one mobile-UTRAN connection uses resources from more than one RNS (see Figure 5.4), the RNCs involved have two separate logical roles (*with respect to this mobile-UTRAN connection*):

- *Serving RNC (SRNC).* The SRNC for one mobile is the RNC that terminates both the Iu link for the transport of user data and the corresponding RAN application part (RANAP) signalling to/from the CN (this connection is referred to as the RANAP connection). The SRNC also terminates the RRC Signalling, i.e. the signalling protocol between the UE and UTRAN. It performs the L2 processing of the data to/from the radio interface. Basic Radio Resource Management operations, such as the mapping of Radio Access Bearer (RAB) parameters into air interface transport channel parameters, the handover decision, and outer loop power control, are executed in the SRNC. The SRNC may also (but not always) be the CRNC of some Node B used by the mobile for connection with UTRAN. One UE connected to UTRAN has one and only one SRNC.
- *Drift RNC (DRNC).* The DRNC is any RNC, other than the SRNC, that controls cells used by the mobile. If needed, the DRNC may perform macrodiversity combining and splitting. The DRNC does not perform L2 processing of the user plane data, but routes

the data transparently between the Iub and Iur interfaces, except when the UE is using a common or shared transport channel. One UE may have zero, one or more DRNCs.

Note that one physical RNC normally contains all the CRNC, SRNC and DRNC functionality.

Problem 4.b.ii

Control channel signalling plane

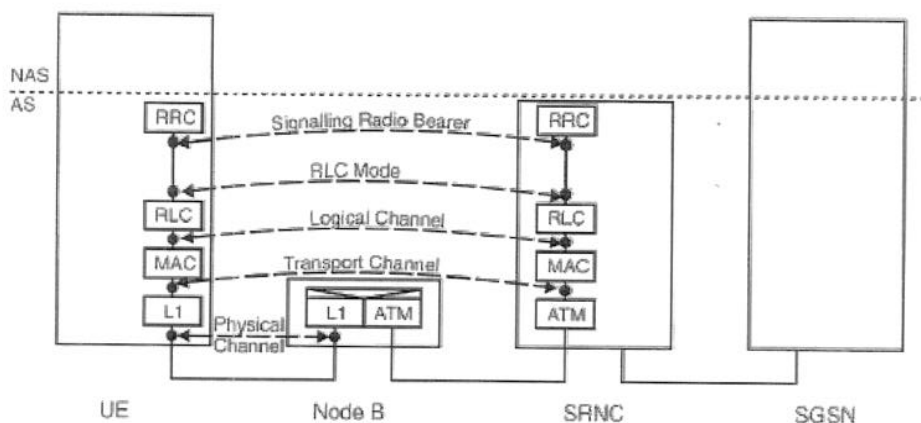

Problem 4.c.i

protocol. The main RRC functions are:

- broadcast of system information, related to access stratum and NAS;
- paging;
- initial cell selection and reselection in idle mode;
- establishment, maintenance and release of an RRC connection between the UE and UTRAN;
- control of RBs, transport channels and physical channels;
- control of security functions (ciphering and integrity protection);
- integrity protection of signalling messages;
- UE measurement reporting and control of the reporting;
- RRC connection mobility functions;
- support of SRNS relocation;
- support for downlink outer loop power control in the UE;
- open-loop power control;
- CBS-related functions;
- support for UE Positioning functions.

Problem 4.c.ii

RNC states

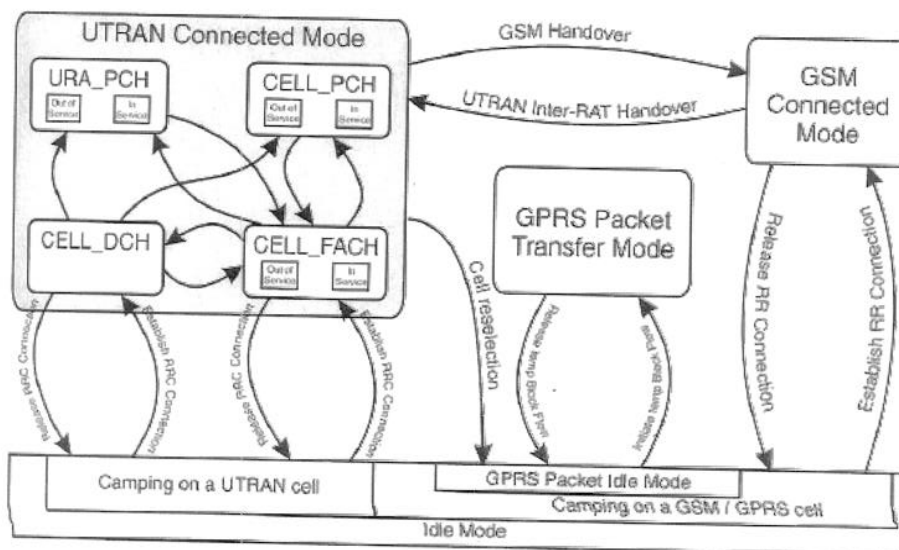

CELL_DCH state

A UE is in the CELL_DCH state when it is assigned a dedicated physical channel (DPCH) either in response to the RRC connection request, or through some UTRAN controlled bearer reconfiguration procedure.

In the CELL_DCH state, the UE location is known by the UTRAN to the cell level. In the CN, the UE location is known to the serving RNC.

Whilst in the CELL_DCH state the UE has access not only to the allocated dedicated resource but also to any shared resources that were allocated. The UE can dynamically utilise these resources within the confines of the transport format combination (TFC)

CELL_FACH state

A UE is in the CELL_FACH state if it has been assigned to use common channels in the UTRAN as either part of the RRC connection request process, or some form of RB reconfiguration process.

While in the CELL_FACH state, the UE has access to the common channels that were assigned as part of the bearer establishment process by the RNC. The common channels that are assigned depend upon traffic volume estimates. For low volume in the uplink the UE will most likely be assigned a RACH channel, whilst for high volume in the uplink it might be assigned a CPCH transport channel.

In the CELL_FACH state, the UE location is known to the cell level. If the UE notices any change in cell identity, it performs a cell update procedure. The UE is addressed by the cell radio network temporary identifier (c-RNTI) (see Section 2.4) from the RNC that is controlling the cell that the UE is present in.

The UE can move to any of the other connected states as directed by the UTRAN. Such moves are a consequence of changes in traffic loading in either the UE or the cell.

CELL_PCH state

A UE is in the CELL_PCH state if it was previously in the CELL_FACH or Cell_DC state and the flow of traffic stopped. In the CELL_PCH state, the UE has no upli resources that it can use. The UE monitors the paging channel using the assign discontinuous reception (DRX) parameters. If the UE notices that the cell has change it will initiate a cell update procedure after moving back to the CELL_FACH state. the UE is paged by the UTRAN, the UE must move back to the CELL_FACH st to respond with an appropriate uplink access.

The purpose of the CELL_PCH state is to allow the UE to use DRX to conser battery power, but still allow the network rapid access to the UE by knowing that or one cell needs to be paged.

URA_PCH state

The URA_PCH state is very similar to the CELL_PCH state except that the location the UE is now only known to the URA level. The URA is a collection of cells similar a GSM location area. The UE monitors the URA and performs URA updates whene it notices that the URA has changed. The UE has no uplink access in the URA_PC

Problem 4.d.i

Gram matrix

1.0000	0	0	0.5
0	1.0	0	0.5
0	0	1.0	-0.5
0.5	0.5	-0.5	1.0

Problem 4.d.i

SS^T

1.0000	0.5000	0	0
0.5000	1.0000	-0.5000	-0.5000
0	-0.5000	1.0000	0
0	-0.5000	0	1.0000

Problem 4.e.i

The Gram matrix is

1.0000	- 0.5774i	- 0.5774i	- 0.5774i
0.5774i	1.0000	0.5774i	- 0.5774i
0.5774i	0.5774i	1.0000	0.5774i
0.5774i	0.5774i	- 0.5774i	1.0000

$$\mathbf{S}\mathbf{S}^H = \begin{bmatrix} 2 & 0 \\ 0 & 2 \end{bmatrix}$$

Also we have

$$\mathbf{s}_1^H \mathbf{S} = \begin{bmatrix} 1 & -0.5774i & -0.5774i & -0.5774i \end{bmatrix}$$

$$|\mathbf{s}_1^H \mathbf{S}|^2 = 2 = \frac{K}{N}$$

and

$$\mathbf{s}_2^H \mathbf{S} = \begin{bmatrix} 0.5774i & 1 & 0.5774i & -0.5774i \end{bmatrix}$$

$$|\mathbf{s}_2^H \mathbf{S}|^2 = 2 = \frac{K}{N}$$

We further have

$$\mathbf{s}_3^H \mathbf{S} = \begin{bmatrix} 0.5774i & -0.5774i & 1 & 0.5774i \end{bmatrix}$$

$$|\mathbf{s}_3^H \mathbf{S}|^2 = 2 = \frac{K}{N}$$

also

$$\mathbf{s}_4^H \mathbf{S} = \begin{bmatrix} 0.5774i & 0.5774i & -0.5774i & 1 \end{bmatrix}$$

$$|\mathbf{s}_4^H \mathbf{S}|^2 = 2 = \frac{K}{N}$$

Hence the codes satisfy the Welch Bound Equality.

Problem 4.e.ii

SNR is $30/4=7.5$ at the output of each despreading unit.

Problem 4.e.iii

Welch Bound Equality capacity is $\log_2(1+15)=4$.

Sum capacity for the complex codes $2 \log_2(1+7.5)=6.1749$