

EE 3.14 Power Electronics and Machines**Information for Students****Constants:**

Boltzmann constant: $1.38 \times 10^{-23} \text{ m}^2 \text{ kg s}^{-2} \text{ K}^{-1}$
Charge on the Electron: $1.6 \times 10^{-19} \text{ C}$

1. A switch-mode power supply (SMPS) is to be designed to provide the high voltage supply of an LCD backlight for a battery operated piece of equipment. The battery voltage is 10 V and the backlight requires 100 V (the polarity of which is not important). Two approaches are to be compared: a buck-boost circuit and a flyback circuit. Both circuits are to be operated in discontinuous mode.
- a) For the buck-boost circuit an inductor of 20 μH is to be used and the operating frequency will be 20 kHz.
- i) Show that the energy transferred from input to output per switch cycle is:
- $$E = \frac{(V_{I_{on}})^2}{2L} \quad [3]$$
- ii) Calculate the duty-cycle required to supply 0.05A to the backlight at the voltage of 100 V. [4]
- iii) Confirm whether the circuit will be in discontinuous operation. [3]
- iv) Calculate the voltage imposed across the transistor during the off state. [1]
- b) For the flyback circuit, a mutually coupled pair of inductors is to be used where the primary inductance is 20 μH and the turns-ratio is 1:6. The operating frequency will again be 20 kHz.
- i) Demonstrate that the circuit should be operated with the same duty-cycle as the buck-boost circuit for a load of 0.05 A at 100 V if discontinuous operation is assumed. [2]
- ii) Confirm whether the circuit will be in discontinuous operation. [3]
- iii) Calculate the voltage imposed across the transistor in the off-state assuming leakage inductance to be negligible. [2]
- iv) Discuss the relative merits of this circuit with respect to the buck-boost. [2]

- 2.
- a) Discuss why EMC is an important factor in the design of power electronic equipment. [4]
 - b) An AC/DC power converter based on a boost circuit is commonly used instead of an uncontrolled diode rectifier in order to meet EMC standards.
 - i) Explain why a diode rectifier gives a poor current spectrum. [3]
 - ii) Describe how the AC/DC power converter is controlled to operate as a rectifier with good EMC properties and compare the resulting current spectrum to that of the diode rectifier. [6]
 - iii) Explain why the AC input current of the power converter suffers distortion near the zero-crossing. [2]
 - iv) Explain why the DC output of the power converter has a significant voltage ripple at twice the input frequency. [2]
 - c) Describe why the EMC properties of a Ćuk SMPS would be expected to be better than those of a Buck-Boost SMPS. [3]

3. This question concerns the operation of power semiconductor devices used in the circuit shown in figure Q3.1.

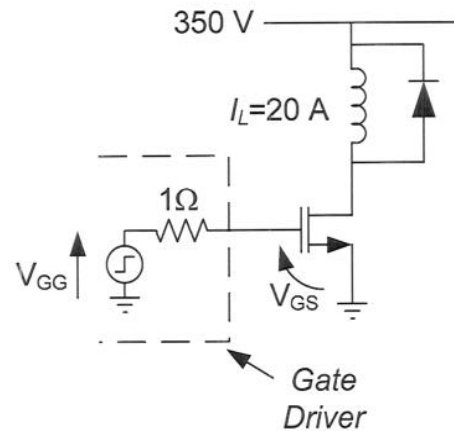

Figure Q3.1 MOSFET switching a diode clamped inductive load

- a) You are required to design a diode for use in the circuit of Figure Q3.1.
- i) Explain why power diodes are generally created with a 3 layer *pin* structure rather than a simple 2 layer *pn* structure. [4]
 - ii) Estimate the minimum length required of diode in this application. State any assumptions you make. The maximum field strength before breakdown in silicon is 10 MV/m. [3]
- b) The switching waveforms of the MOSFET shown in Figure Q3.1 are shown below in Figure Q3.2.

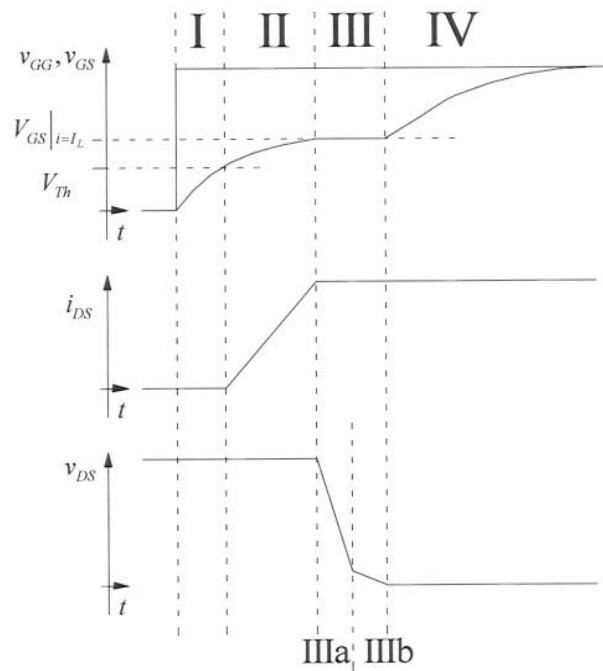

Figure Q3.2 MOSFET switching waveforms

- i) Explain the operation of the circuit during the turn on process (the periods I to IV in figure Q3.2). [8]
- ii) By calculating the current rise-time and voltage fall-time, calculate the energy loss in the MOSFET due to a turn-on event. Assume the following:

$$I_D = k(V_{GS} - V_{Th})^2;$$

$$K=0.4 \text{ A/V}^2;$$

$$V_{Th}=3 \text{ V};$$

$$C_{gs}=7\text{nF} \text{ and is constant};$$

$$C_{gd}=0.2\text{nF} \text{ and is constant};$$

$$V_{GG} \text{ transitions instantly from } 0 \text{ V to } 15 \text{ V};$$

Drain current rises linearly.

4. This question concerns losses in DC-DC power converters.

- a) Explain why the switching losses in the circuit of Figure Q4.1 are lower than the switching losses in the circuit of Figure Q4.2, when the supply voltage, on-state steady current and gate drive circuit are the same in each case. [4]

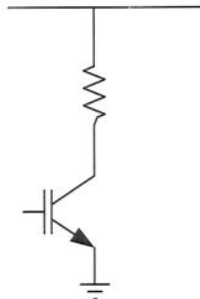

Figure Q4.1 IGBT with resistive load

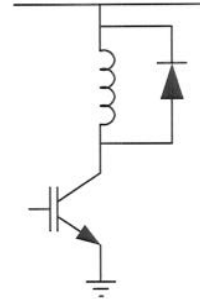

Figure Q4.2 IGBT with inductive load

- b) The circuit of Figure Q4.3 shows a buck converter, with 3 additional components added (inside the dotted line)

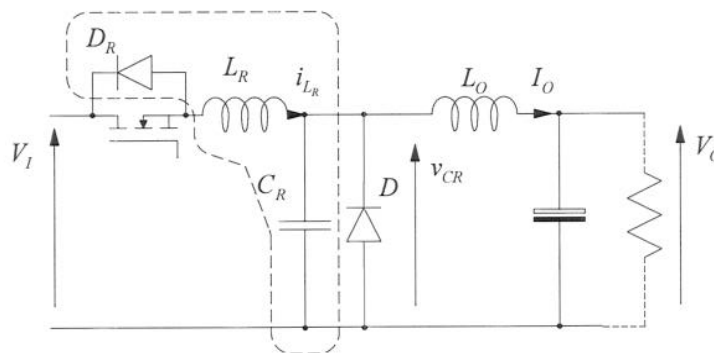

Figure Q4.3 Buck converter with 3 additional components

- i) What type of power converter is this? [1]
- ii) Explain the purpose of these additional components. How do they influence the turn on and turn off voltage and current waveforms in the MOSFET? [4]
- c) The converter operates with a 50 % duty cycle, and has an output voltage of 5 V with a 10 W load. The freewheeling diode, D, conducts with a duty cycle of 50 %. It is assumed that the diode operates at its maximum allowed junction temperature of 130 °C.
- i) What is the power dissipation in the diode? The diode has a reverse saturation current of 1×10^{-12} A and obeys the Shockley equation. [3]
- ii) The diode is operated without a heat-sink and as a consequence there is a high thermal resistance between the junction and the air. If this resistance is 60 °C/W, what is the maximum room temperature in which the device can operate? [2]

- iii) The input voltage to the circuit is 24 V. What is the minimum blocking voltage that the diode, D, must be able to withstand without breaking down? Explain your answer. [2]
- d) The circuit of Figure Q4.4 shows a buck converter, with 3 additional components added (inside the dotted line) in a different configuration to Figure Q4.3.

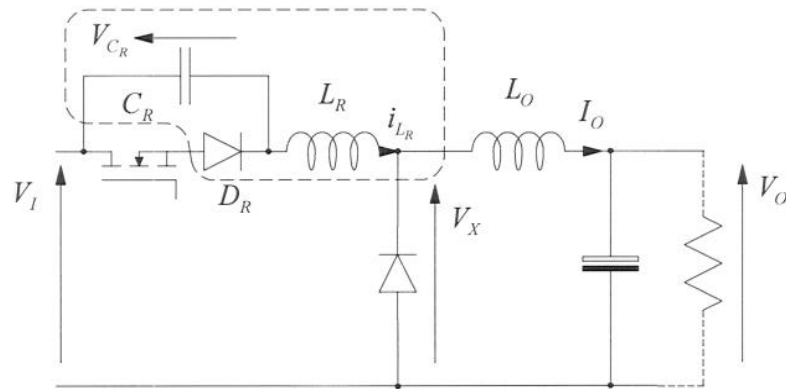

Figure Q4.4 Buck converter with 3 additional components in different configuration

- i) What type of converter is this? [1]
- ii) Explain the purpose of these additional components in this circuit. How do they influence the turn on and turn off voltage and current waveforms in the MOSFET? [3]

5. A servo using feedback control of speed is required and a DC motor or an induction motor could be used.
- i) Describe the power converters used in each case and the form of modulation to be employed. [5]
 - ii) Describe the control structures used in each case. (Controlled-slip operation of the induction machine is sufficient.) [7]
 - iii) Describe any advantages one choice has over the other. [2]
 - iv) State how the supply to each machine is changed to achieve braking torque. [2]
 - v) State how the supply to each machine is changed to achieve reverse rotation. [2]
 - vii) The DC input power required for both drives is to come from a 3-phase mains connection. Describe a circuit that could provide the AC/DC conversion and be able to process power flow in either direction. [2]

6.

- a) In an open-loop induction machine drive, the stator voltage is varied in proportion to the frequency over the middle range of frequencies. Describe why a different relationship is followed at low and high frequencies. [3]
- b) Figure Q3 shows an approximate equivalent circuit for an induction machine (one in which the magnetising inductance has been moved to the stator terminals). It is to be supplied from an inverter with a DC input voltage of 650 V. The designed level of magnetising flux linkage (in RMS form) is $\Psi(\text{design}) = 0.70$ Wb.

The circuit parameters of the machine are:

$$L_M = 0.035 \text{ H};$$

$$L_S + L'_R = 0.002 \text{ H};$$

$$R_S = 0.1 \ \Omega;$$

$$R_R = 0.1 \ \Omega;$$

$$P = 1;$$

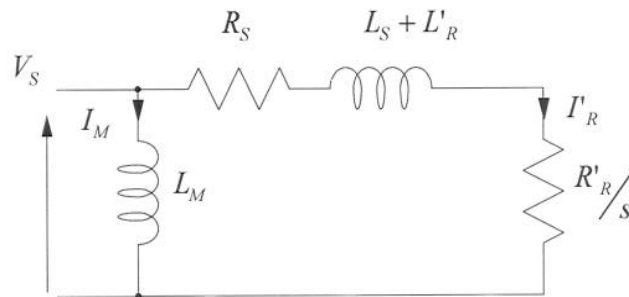

Figure Q3 Approximate equivalent circuit of an induction machine

- i) Calculate the required magnetising current and the stator voltage that needs to be applied at 50 Hz to achieve the designed flux linkage. [3]
- ii) For 50 Hz operation, the machine will operate at a slip of 50 rpm when producing rated power. Calculate the (referred) rotor current that flows at this condition, its angle with respect to the flux linkage and the torque. [4]
- iii) Calculate the stator voltage required at 75 Hz to again achieve the designed flux linkage. Check the required voltage against the available DC voltage for the inverter and determine if the machine must operate in field weakening. [3]
- iv) By considering Kirchoff's voltage law for the rotor branch, show that $x=1/s$ can be found from the following equation: [2]
- $$0 = |V_S|^2 - (I'_R 2\pi f (L_S + L'_R))^2 - I'^2_R R_S^2 - x(2I'^2_R R'_R R_S) - x^2(I'^2_R R'^2_R)$$
- v) Calculate the slip required when operating at 75 Hz with the voltage found in (b)(iii) to draw the same rotor current *magnitude* as in (b)(ii) and calculate the phase angle of the current in this condition. [3]
- vi) Calculate the angle of the rotor current and the torque for 75 Hz operation. [2]