

## Solutions 2008

Solution to Question 1

(a) 132/11 kV 90 MVA transformer has a per unit leakage reactance of 0.1 p.u. on rating.

$$(i) Z_{base_{hv}} = \frac{U_{hv}^2}{S_b} = \frac{132^2 \cdot 10^6}{90 \cdot 10^6} = 193.6 \Omega, X_{hv} = x \cdot Z_{base_{hv}} = 0.1 \cdot 193.6 = 19.36 \Omega$$

$$Z_{base_{lv}} = \frac{U_{lv}^2}{S_b} = \frac{11^2 \cdot 10^6}{90 \cdot 10^6} = 1.34 \Omega, X_{lv} = x \cdot Z_{base_{lv}} = 0.1 \cdot 1.34 = 0.134 \Omega \quad [2]$$

(ii) If reactance is on the low-voltage side, then the value is:

$$x = 0.1 (11^2 / 90) (150 / 11.5^2) = 0.152 \text{ p.u.}$$

If reactance is on high voltage side then value is:

$$x = 0.1 (132^2 / 90) (150 / 132^2) = 0.167 \text{ p.u.}$$

The remaining ideal transformation is:

$$t = (132 / 132) / (11 / 11.5) = 1.045$$

[2]

(b) For a transmission circuit given in Figure 1.1, we show:

$$\overline{S}_r = P_r + jQ_r = \overline{V}_r \cdot \overline{I}^*$$

$$\overline{I} = \frac{P_r - jQ_r}{\overline{V}_r^*}$$

$$\overline{V}_s = \overline{V}_r + (R + jX) \cdot \overline{I}$$

$$(i) \overline{V}_s = \overline{V}_r + (R + jX) \cdot \left( \frac{P_r - jQ_r}{\overline{V}_r^*} \right) \quad [2]$$

$$\overline{V}_r = \overline{V}_r^* = V_r \angle 0^\circ = V_r$$

$$\overline{V}_s = V_r + \left( \frac{RP_r + XQ_r}{V_r} \right) + j \left( \frac{XP_r - RQ_r}{V_r} \right)$$

$$(ii) \text{ Active losses} = \left( \frac{S_r}{V_r} \right)^2 \cdot R = I^2 \cdot R; \text{ Reactive losses} = \left( \frac{S_r}{V_r} \right)^2 \cdot X = I^2 \cdot X$$

The active and reactive powers supplied by the source:

$$P_G = P_r + I^2 \cdot R \quad Q_G = Q_r + I^2 \cdot X \quad [2]$$

(c) For the network shown in Figure 1.1 we have:

$$\bar{I} = \frac{\bar{V}_s - \bar{V}_r}{jX}$$

$$(i) \quad S = \bar{V}_s \cdot \bar{I}^* = \bar{V}_s \cdot \frac{\bar{V}_s^* - \bar{V}_r^*}{-jX} = \frac{V_s^2 - V_s V_r e^{j(\delta_s - \delta_r)}}{-jX} = \frac{jV_s^2 - V_s V_r e^{j(\delta_s - \delta_r + 90^\circ)}}{X}$$

$$= \frac{jV_s^2 - V_s V_r [(\cos(\delta_s - \delta_r + 90^\circ) + j \sin(\delta_s - \delta_r + 90^\circ))]}{X}$$

$$(ii) \quad S = \frac{V_r \cdot V_s}{X} \sin(\delta_s - \delta_r) + j \frac{V_s^2 - V_r V_s \cos(\delta_s - \delta_r)}{X}$$

$$P = \frac{V_s \cdot V_r}{X} \sin(\delta_s - \delta_r) \quad \text{P flow requires a difference in phase angle}$$

$$Q = \frac{V_s^2 - V_s \cdot V_r \cos(\delta_s - \delta_r)}{X} \quad \text{Q flows requires a difference in voltage magnitude}$$

If both angles are the same then the sine will be zero, which implies that active power will be zero as well. For a small difference in angles the sine is the same as the difference (in radians), and therefore the active power is proportional to the difference in phase angles.

For a small difference in phase angles the cosine is close to one, and if voltage at the receiving end is the same as voltage at the sending end, the reactive power will be zero.

$$(iii) \quad P = \frac{V_s \cdot V_r}{X} \sin(\delta_1 - \delta_2) = P_{\max} \sin(\delta_1 - \delta_2)$$

For the angle difference of  $90^\circ$ , the sine becomes one.

(d)

(i) Positive sequence component:

$$\bar{I}^1 = \bar{I}_a + a\bar{I}_b + a^2\bar{I}_c$$

Negative sequence component:

$$\bar{I}^2 = \bar{I}_a + a^2\bar{I}_b + a\bar{I}_c$$

If phasors are identical (i.e.  $\bar{I}_a = \bar{I}_b = \bar{I}_c$ ), the above components are proportional to  $(1 + a + a^2)$ , which is equal to zero.

(ii)

$$\begin{aligned} \bar{I}_n &= \bar{I}_a + \bar{I}_b + \bar{I}_c \\ &= (\bar{I}_a^0 + \bar{I}_a^1 + \bar{I}_a^2) + (\bar{I}_b^0 + \bar{I}_b^1 + \bar{I}_b^2) + (\bar{I}_c^0 + \bar{I}_c^1 + \bar{I}_c^2) \\ &= (\bar{I}_a^0 + \bar{I}_b^0 + \bar{I}_c^0) + \underbrace{(\bar{I}_a^1 + \bar{I}_b^1 + \bar{I}_c^1)}_0 + \underbrace{(\bar{I}_a^2 + \bar{I}_b^2 + \bar{I}_c^2)}_0 \\ &= 3\bar{I}^0 \end{aligned}$$

$$\overline{I}_a^1 + \overline{I}_b^1 + \overline{I}_c^1 = \overline{I}_a^1 + a\overline{I}_a^1 + a^2\overline{I}_a^1 = 0$$

$$\overline{I}_a^2 + \overline{I}_b^2 + \overline{I}_c^2 = \overline{I}_a^2 + a^2\overline{I}_a^2 + a\overline{I}_a^2 = 0$$

$$\overline{I}_a^0 + \overline{I}_b^0 + \overline{I}_c^0 = \overline{I}^0 + \overline{I}^0 + \overline{I}^0 = 3\overline{I}^0$$

If there is no current  $I_m$ , there would not be current  $I_0$ .

[2]

(iii)

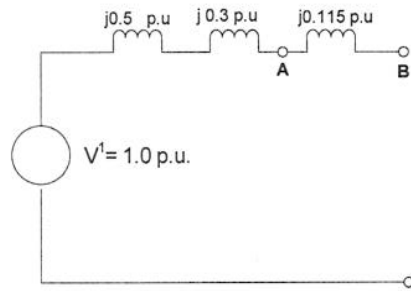

Positive sequence equivalent circuit

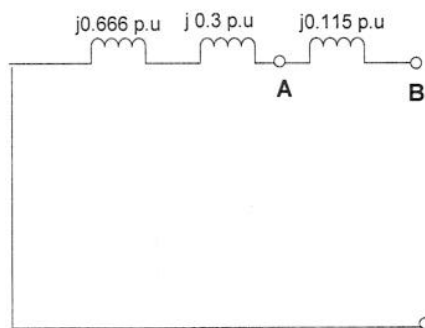

Negative sequence equivalent circuit

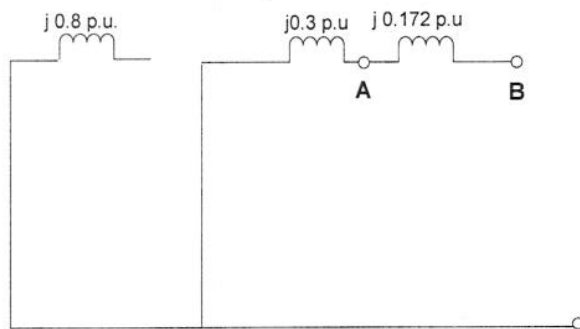

Zero sequence equivalent circuit

[3]

**Solution to Question 2**

- (a) The states of the generation system with the appropriate probabilities are given in the following table.

STATE	State Probability	Probability that Generation is equal to or greater than State
350 MW	0.90307	0.90307
300 MW	0.02793	0.93100
250 MW	0.04753	0.97853
200 MW	0.00147	0.98000
150 MW	0.01843	0.99843
100 MW	0.00057	0.99900
50 MW	0.00097	0.99997
0 MW	0.00003	1.00000

[5]

If the system load is 260 MW, at least 300 MW of available capacity is necessary to fully cover that demand. This means the probability of not being able to cover the demand is equal to  $1 - P(\text{Gen} \geq 300 \text{ MW})$ , which is 0.069, or 6.9%.

[2]

- (b) The energy required to lift 25 tonnes of water to the height of 36 m is:  $E = m g h = 25,000 \cdot 9.81 \cdot 36 = 8.829 \text{ MJ}$ . In kilowatt-hours, this amounts to 2.45 kWh. With the price of 8 p/kWh, the cost of electricity required to lift the water equals 19.62 p.

[3]

- (c) The maximum reactive power that the generator can absorb is determined by the condition with the internal voltage  $E = 0$ . In that case, the theoretical maximum capacitive reactive power (in per unit values) can be obtained from the generator capability chart:

$$Q_{cap,max} = V_t^2 / X_d = 0.58 \text{ pu}$$

In absolute terms, this amounts to 368.3 MVar (cap).

[3]

The active power export in this case is equal to 0.

[2]

- (d) The coincidence coefficients for the two customer groups are determined as follows:

$$j_A = j_{A\infty} + \frac{1-j_{A\infty}}{\sqrt{n_A}} \quad j_B = j_{B\infty} + \frac{1-j_{B\infty}}{\sqrt{n_B}}$$

which yields:  $j_A = 0.24$ ,  $j_B = 0.55$ . Total group peak can be found by multiplying the single household peak with the number of households and the corresponding coincidence coefficient:

$$P_{Amax} = P_A n_A j_A \quad P_{Bmax} = P_B n_B j_B$$

which gives:  $P_{Amax} = 960$  kW,  $P_{Bmax} = 1,100$  kW. This makes the total peak load of the substation (under the assumption that peaks for both A and B are simultaneous):  
 $P_{total} = 2,060$  kW.

[5]

### Solution to Question 3

(a) Unlike active power, reactive power cannot be transmitted across long distances, for the following reasons:

- Transmitting reactive power requires a voltage drop that would become unacceptable for long distances.
- Since  $X \gg R$ , the reactive losses are much larger than the active losses and the transmission of reactive power would be inefficient.
- Therefore, we need sources of reactive power around the network.

[3]

(b)

(i)  $Y_{\text{bus}}$  matrix is obtained as follows:

$$z_{12} = 0 + j0.1 \text{ p.u.}$$

$$y_{12} = \frac{1}{z_{12}} = -j10 \text{ p.u.}$$

$$z_{13} = 0 + j0.2 \text{ p.u.}$$

$$y_{13} = \frac{1}{z_{13}} = -j5 \text{ p.u.}$$

$$z_{23} = 0 + j0.25 \text{ p.u.}$$

$$y_{23} = \frac{1}{z_{23}} = -j4 \text{ p.u.}$$

$$Y_{11} = y_{12} + y_{13} = -j15 \text{ p.u.}$$

$$Y_{22} = y_{12} + y_{23} = -j14 \text{ p.u.}$$

$$Y_{33} = y_{13} + y_{23} = -j9 \text{ p.u.}$$

$$Y_{12} = Y_{21} = -y_{12} = j10 \text{ p.u.}$$

$$Y_{13} = Y_{31} = -y_{13} = j5 \text{ p.u.}$$

$$Y_{23} = Y_{32} = -y_{23} = j4 \text{ p.u.}$$

$$Y = j \begin{bmatrix} -15 & 10 & 5 \\ 10 & -14 & 4 \\ 5 & 4 & -9 \end{bmatrix}$$

[3]

(ii)

$$s_2 = 1.5 + j0.8 \text{ p.u.}$$

$$V_1 = ?$$

$$V_2 = ?$$

$$P_1 = ?$$

$$Q_1 = ?$$

$$P_2 = ?$$

$$Q_2 = ?$$

$$\begin{aligned}
V_1^{(0)} &= 1 + j0 && \text{Slack bus} \\
V_2^{(0)} &= 1 + j0 && \text{PQ bus} \\
V_3^{(0)} &= 1 + j0 && \text{PV bus}
\end{aligned}$$

**FIRST ITERATION:**

$$V_2^{(1)} = \frac{1}{Y_{22}} \cdot \left( \frac{S_2^*}{V_2^{(0)*}} - Y_{21} \cdot V_1^{(0)} - Y_{23} \cdot V_3^{(0)} \right) = 0.9429 - j0.1071 \text{ p.u.}$$

$$\Delta V_2^{(1)} = |V_2^{(1)} - V_2^{(0)}| = 0.1214 \text{ p.u.}$$

$$V_3^{(\bar{1})} = \frac{1}{Y_{33}} \cdot \left( \frac{S_3^{(0)*}}{V_3^{(0)*}} - Y_{31} \cdot V_1^{(0)} - Y_{32} \cdot V_2^{(1)} \right) = 0.9746 - j0.0476 \text{ p.u.}$$

$$V_3^{(1)} = \frac{V_3^{(\bar{1})}}{|V_3^{(\bar{1})}|} = 0.9988 - j0.0488 \text{ p.u.}$$

$$\Delta V_3^{(1)} = |V_3^{(1)} - V_3^{(0)}| = 0.0488 \text{ p.u.}$$

$$S_2^{(1)} = V_2^{(1)} \cdot \left( Y_{21} \cdot V_1^{(0)} + Y_{22} \cdot V_2^{(1)} + Y_{23} \cdot V_3^{(1)} \right)^* = -1.3048 - j0.7952 \text{ p.u.}$$

$$S_1^{(1)} = V_1^{(0)} \cdot \left( Y_{12} \cdot V_2^{(1)} + Y_{11} \cdot V_1^{(0)} + Y_{13} \cdot V_3^{(1)} \right)^* = 1.3154 + j0.5774 \text{ p.u.}$$

$$Q_3^{(1)} = -\text{imag}(V_3^{(1)} (Y_{31} \cdot V_1^{(0)} + Y_{32} \cdot V_2^{(1)} + Y_{33} \cdot V_3^{(1)})) = j0.2181 \text{ p.u.}$$

**SECOND ITERATION:**

$$V_2^{(2)} = \frac{1}{Y_{22}} \cdot \left( \frac{S_2^*}{V_2^{(1)*}} - Y_{21} \cdot V_1^{(0)} - Y_{23} \cdot V_3^{(1)} \right) = 0.9271 - j0.1193 \text{ p.u.}$$

$$\Delta V_2^{(2)} = |V_2^{(2)} - V_2^{(1)}| = 0.0199 \text{ p.u.}$$

$$V_3^{(\bar{2})} = \frac{1}{Y_{33}} \cdot \left( \frac{S_3^{(1)*}}{V_3^{(1)*}} - Y_{31} \cdot V_1^{(0)} - Y_{32} \cdot V_2^{(2)} \right) = 0.9746 - j0.0476 \text{ p.u.}$$

$$V_3^{(2)} = \frac{V_3^{(\bar{2})}}{|V_3^{(\bar{2})}|} = 0.9988 - j0.0488 \text{ p.u.}$$

$$\Delta V_3^{(2)} = |V_3^{(2)} - V_3^{(1)}| = 0 \text{ p.u.}$$

$$S_2^{(2)} = V_2^{(2)} \cdot \left( Y_{21} \cdot V_1^{(0)} + Y_{22} \cdot V_2^{(2)} + Y_{23} \cdot V_3^{(2)} \right)^* = -1.4754 - j1.0161 \text{ p.u.}$$

$$S_1^{(2)} = V_1^{(0)} \cdot \left( Y_{12} \cdot V_2^{(2)} + Y_{11} \cdot V_1^{(0)} + Y_{13} \cdot V_3^{(2)} \right)^* = 1.4373 + j0.7352 \text{ p.u.}$$

$$Q_3^{(2)} = -\text{imag}(V_3^{(2)} (Y_{31} \cdot V_1^{(0)} + Y_{32} \cdot V_2^{(2)} + Y_{33} \cdot V_3^{(2)})) = j0.2788 \text{ p.u.}$$

[14]

**Solution to Question 4**

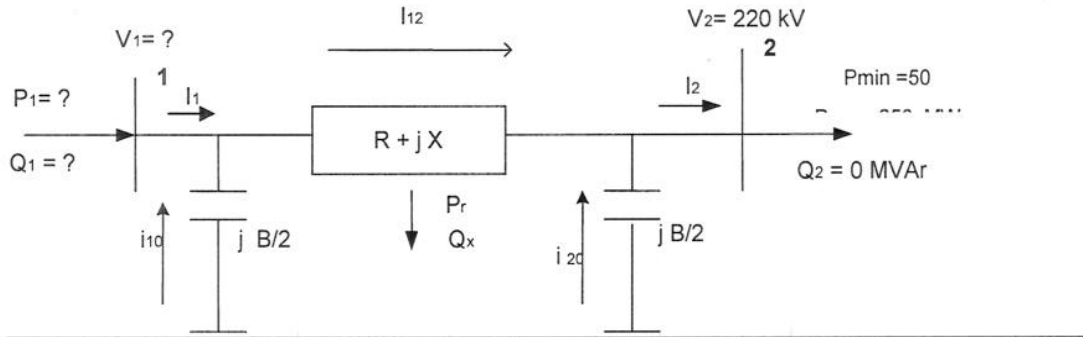

Per unit calculations:

$$S_b = 100 \text{ MVA}$$

$$V_b = 220 \text{ kV}$$

$$Z_b = \frac{V_b^2}{S_b} = 484 \Omega$$

$$r = \frac{r' \cdot L}{Z_b} = 0.0207 \text{ p.u.}$$

$$x = \frac{x' \cdot L}{Z_b} = 0.0207 \text{ p.u.}$$

$$z = r + jx = 0.027 + j0.027 \text{ p.u.}$$

$$b = b' \cdot L \cdot Z_b = 1.4520 \text{ p.u.}$$

(a) and (b) for demand level 50 MW:

$$s_2 = \frac{S_2}{S_b} = 0.5 \text{ p.u.}$$

$$v_2 = \frac{V_2}{V_b} = 1 \text{ p.u.}$$

$$i_2 = \frac{S_2^*}{v_2} = 0.50 p.u$$

$$i_{20} = -j \frac{b}{2} \cdot v_2 = 0 - j0.726 p.u.$$

$$i_{12} = i_2 - i_{20} = 0.5 + j0.726 p.u.$$

$$\Delta v_{12} = i_{12} \cdot z = -0.0047 + j0.0253 p.u.$$

$$v_1 = \Delta v_{12} + v_2 = 0.9953 + j0.0253 p.u.$$

$$V_1 = v_1 \cdot V_b = 218 + j5 kV$$

$$i_{10} = -j \frac{b}{2} \cdot v_1 = 0.0184 - j0.7226 p.u.$$

$$i_1 = i_{12} - i_{10} = 0.4816 + j1.4486 p.u$$

$$s_1 = v_1 \cdot i^* = 0.5161 - j1.4296 p.u$$

$$S_1 = s_1 \cdot S_b = 51 MW - j142 M var$$

$$P_1 = 51 MW; Q_1 = -142 MVar$$

[8]

(a) and (b) for demand level 250 MW:

$$s_2 = \frac{S_2}{S_b} = 2.5 p.u.$$

$$v_2 = \frac{V_2}{V_b} = 1 p.u.$$

$$i_2 = \frac{S_2^*}{v_2} = 2.50 p.u$$

$$i_{20} = -j \frac{b}{2} \cdot v_2 = 0 - j0.726 p.u.$$

$$i_{12} = i_2 - i_{20} = 2.5 + j0.726 p.u.$$

$$\Delta v_{12} = i_{12} \cdot z = 0.0367 + j0.0667 p.u.$$

$$v_1 = \Delta v_{12} + v_2 = 1.0367 + j0.0667 p.u.$$

$$V_1 = v_1 \cdot V_b = 228 + j14 kV$$

$$i_{10} = -j \frac{b}{2} \cdot v_1 = 0.0184 - j0.7526 p.u.$$

$$i_1 = i_{12} - i_{10} = 2.4516 + j1.4786 p.u$$

$$s_1 = v_1 \cdot i^* = 2.64 - j1.3694 p.u$$

$$S_1 = s_1 \cdot S_b = 264 MW - j137 M var$$

$$P_1 = 264 MW; Q_1 = -137 MVar$$

[8]

(c) A transmission line generates almost constant reactive power represented by its susceptance. A transmission line absorbs reactive power in its reactance. The absorption depends on the loading condition. If the line is more heavily loaded, it will absorb more reactive power. Therefore, in this example, in a low load condition the generator should absorb more reactive power (-142 MVar) then in a higher load condition (-137 MVar).

[4]

### Solution to Question 5

The information on the generator current implies that its apparent power  $S$  is also equal to 0.8 pu, with  $\cos\theta = 0.9$  (lagging).

- (a) The magnitude of the internal voltage can be found through the geometry of the generator performance chart by using:

$$E = \sqrt{\left(V_t + \frac{S \sin\theta X_d}{V_t}\right)^2 + \left(\frac{S \cos\theta X_d}{V_t}\right)^2} = 2.026 \text{ pu}$$

The angle of the internal voltage is obtained using the following expression:

$$\sin\delta = \frac{S \cos\theta X_d}{E V_t} \Rightarrow \delta = 37.78^\circ \quad [4]$$

- (b) Active and reactive power is calculated as:

$$P = S \cos\theta = 0.72 \text{ pu}, \quad Q = S \sin\theta = 0.3487 \text{ pu} \quad [4]$$

The basic operating point corresponds to point A in Figure 5.1 below.

- (c) (i) With excitation increased by 20%, and same active power, we have  $E = 2.431$  pu, which yields:

$$\delta = \arcsin \frac{P X_d}{E V_t} = 30.70^\circ$$

Reactive power can be obtained from the chart geometry as follows:

$$Q = \sqrt{\left(\frac{E V_t}{X_d}\right)^2 - P^2} - \frac{V_t^2}{X_d} = 0.6325 \text{ pu} \quad [4]$$

The operating point with increased excitation corresponds to point B in Figure 5.1 below.

- (ii) With excitation decreased by 20%, and same active power, we have  $E = 1.621$  pu. Using the same formulas as above yields:  $\delta = 49.98^\circ$ ,  $Q = 0.0245$  pu.

[4]

The operating point with decreased excitation corresponds to point C in Figure 5.1 below.

(d) Generator performance chart:

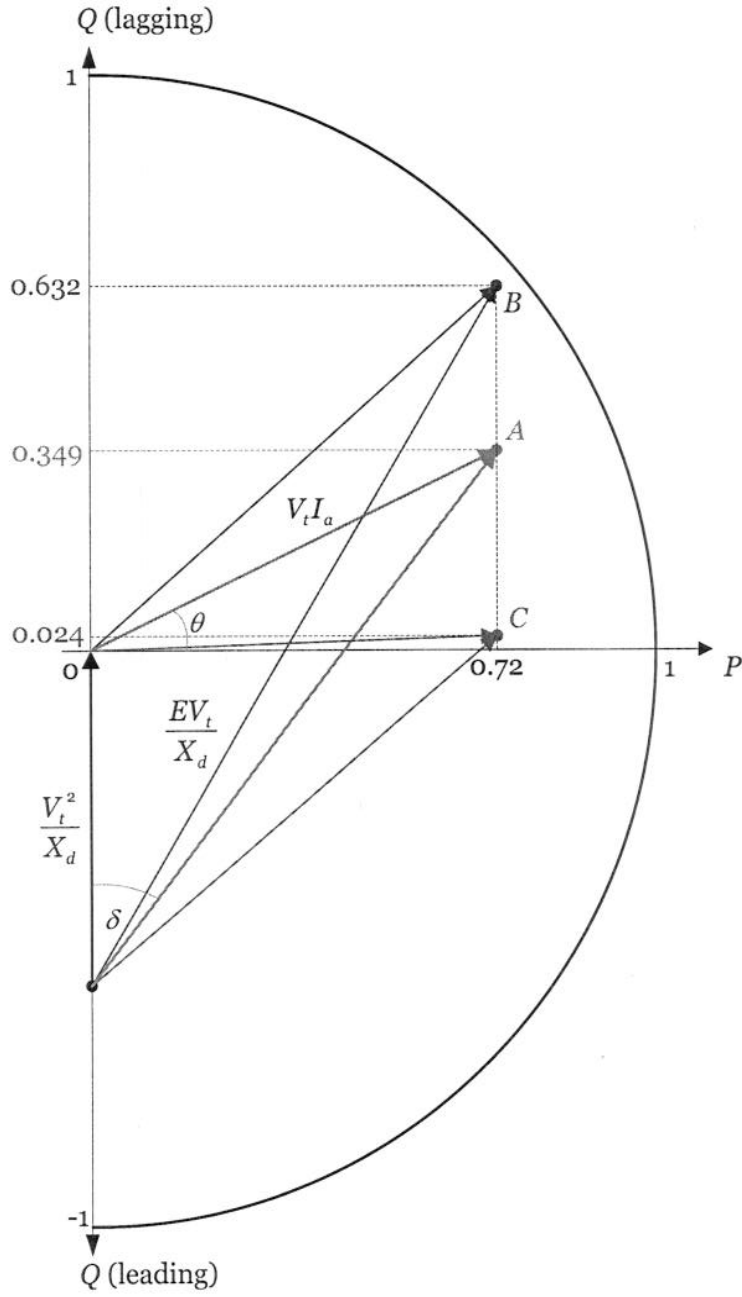

Figure 5.1. Generator performance chart

[4]

### Solution to Question 6

- (a) The symmetrical components methods greatly simplifies the analysis of unbalanced conditions such as unbalanced short-circuit faults. This method allows us to decompose an unbalanced system of voltages or currents into three simpler one-line systems. As opposed to coupled phase voltages and currents in sequence circuits, voltages and currents in symmetrical components are decoupled, making the analysis significantly simpler. [4]

- (b) We first form the A matrix:

$$\mathbf{A} = \begin{bmatrix} 1 & 1 & 1 \\ 1 & a^2 & a \\ 1 & a & a^2 \end{bmatrix}$$

where  $a = 1/\sqrt{3}$ . From  $\mathbf{I}_p = \mathbf{A} \mathbf{I}_s$  we conclude that  $\mathbf{I}_s = \mathbf{A}^{-1} \mathbf{I}_p$ , i.e.

$$\mathbf{I}_s = \begin{bmatrix} I_0 \\ I_1 \\ I_2 \end{bmatrix} = \frac{1}{3} \begin{bmatrix} 1 & 1 & 1 \\ 1 & a & a^2 \\ 1 & a^2 & a \end{bmatrix} \cdot \begin{bmatrix} I_a \\ I_b \\ I_c \end{bmatrix} = \begin{bmatrix} 9.453 \angle 110.81^\circ \\ 11.158 \angle -44.33^\circ \\ 5.272 \angle 7.61^\circ \end{bmatrix}$$

[7]

- (c) We first recalculate all per unit parameters to the 100 MVA base, using the following formula:

$$Z_{new}^{pu} = Z_{old}^{pu} \cdot \frac{S_{B,new}}{S_{B,old}}$$

This results in the following values of system parameters:

*Synchronous generators*

$$\text{G1: } X_1 = X_2 = 0.03 \quad X_0 = 0.01$$

$$\text{G2: } X_1 = X_2 = 0.03 \quad X_0 = 0.01$$

*Transformers*

$$\text{T1: } X_1 = X_2 = X_0 = 0.016$$

$$\text{T2: } X_1 = X_2 = X_0 = 0.016$$

*Transmission lines*

$$\text{TL12: } X_1 = X_2 = 0.05 \quad X_0 = 0.15$$

$$\text{TL13: } X_1 = X_2 = 0.025 \quad X_0 = 0.075$$

$$\text{TL23: } X_1 = X_2 = 0.025 \quad X_0 = 0.075$$

The positive, negative and zero sequence networks are depicted in Figure 6.2.

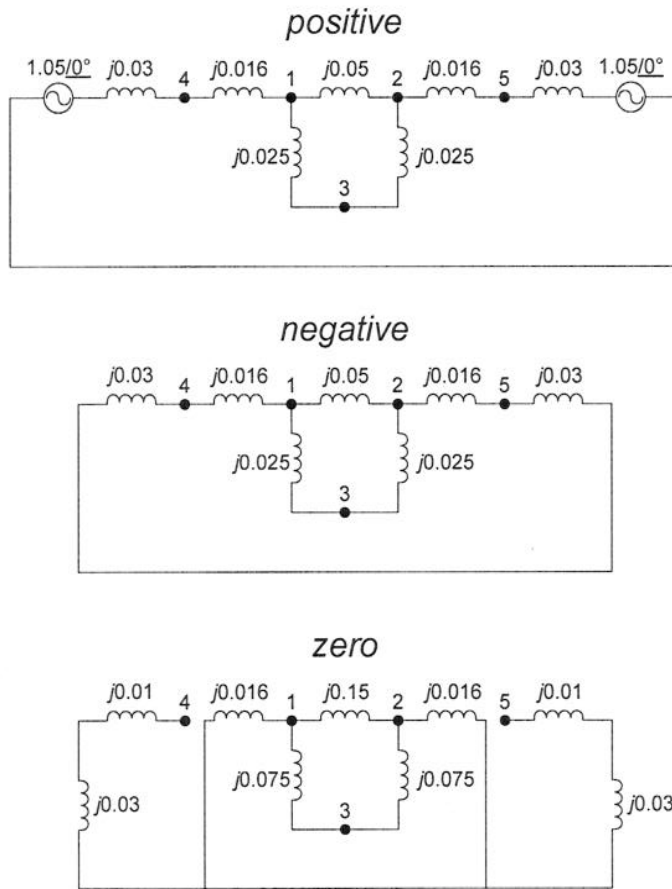

Figure 6.2. Positive, negative and zero sequence networks

[9]

