



**Special instructions for invigilators**

*This section may be omitted.*

**Special instructions for students**

*If both sections here are omitted (the normal case) the whole page may be deleted.*

## Questions

### Question 1: Compulsory question

- (a) Consider a single phase AC circuit shown in Figure Q1. Expressions for generator voltage and current are given by:

$$v(t) = \sqrt{2}V \sin \omega t$$

$$i(t) = \sqrt{2}I \sin(\omega t - \phi)$$

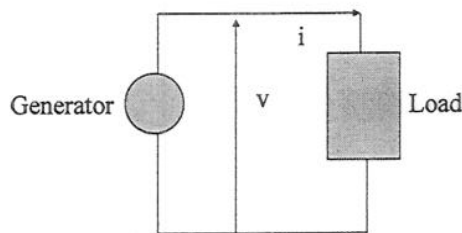

Figure Q1.: Single phase AC circuit

- (i) show that the expression for the instantaneous power can be written in the following form

$$p(t) = \underbrace{P(1 - \cos 2\omega t)}_{A(t)} - \underbrace{Q \sin 2\omega t}_{R(t)}$$

and write the expressions for P and Q

[3]

- (ii) Sketch functions  $p(t)$  and its components  $A(t)$  and  $R(t)$  on the same diagram.

[2]

- (iii) Write the expression for  $A(t)$  and  $R(t)$  for a three phase system (no need for a formal derivation). Explain  $R(t)$ .

[2]

- (b) A 33/11kV 15MVA transformer has a leakage reactance of 10% and series nominal losses of 120kW when loaded at rated current.

- (i) Calculate the leakage reactance as seen from the LV and HV side

[2]

- (ii) Show that the pu series resistance is 0.008 pu

[2]

- (iii) Calculate the efficiency of transformer when it delivers 12MVA at 11kV and 0.9pf

[2]

(iv) What is the voltage drop across the transformer when loaded at 15MVA at 11kV at 1pf and 0pf (lagging). Explain your results.

[2]

(c) A 20 MVA, 11 kV generator has a star connected winding that is earthed through a 10 ohm resistor at its neutral point. It supplies a 30 MVA delta-star connected transformer that steps up the voltage to 66 kV. The star point of the 66 kV winding is solidly earthed. The generator and transformer p.u. reactances, on their respective ratings, are given in Table Q1. Assume the generator is unloaded and that the transformer is connected only to the generator.

Using a base of 20 MVA, calculate the fault current in amperes for a

(i) 3-ph fault on the generator terminals

[2]

(ii) 1-ph fault on a 66 kV terminal of the transformer

[3]

Table Q1

	$X_1$	$X_2$	$X_0$	Rating
Generator	0.2	0.15	0.13	20 MVA
Transformer	0.15	0.15	0.1	30 MVA

## Question 2

Consider a proposed 132kV/11kV substation to be supplied from a very strong 132kV network.

- (i) The substation will supply an 11kV network through one 40 MVA transformer. Show that the minimum value of the per unit reactance based on the rating of the transformer must be at least 0.133 p.u. if the 11kV equipment planned to be installed is rated at 300MVA short-circuit power. [4]
- (ii) calculate the three phase fault level at busbar B. [4]

Table Q2.

	Positive	Negative	Zero
Transformer	0.13	0.13	0.13
Line	0.5	0.5	0.8

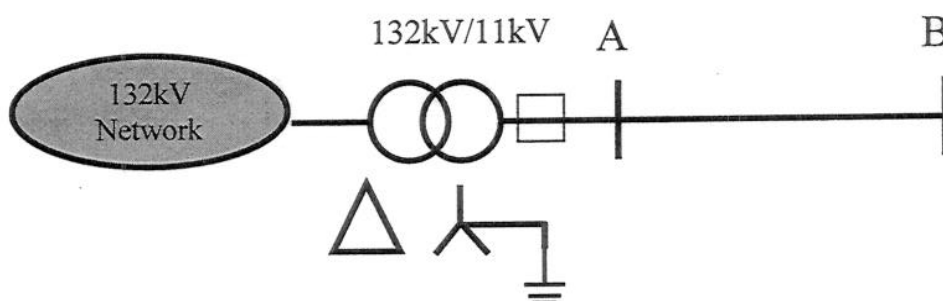

Figure Q2. A simple power system composed of a generator, transformer and transmission line

- (iii) Determine the loading condition that would lead to a maximum voltage drop across the transformer. What will be the value of the maximum voltage drop? [4]
- (iv) This transformer will supply 80 distribution 11/0.4 kV substations of two types. Type A (30 substations), with expected peak demand of 400kW and Type B (50 substations) with peak demand of 650kW. Coincidence coefficients for an infinite number of Type A and Type B substations are 0.6 and 0.8 respectively. Assuming that peaks of both types of distribution substations coincide, calculate the peak demand of the proposed 132kV/11kV substation. [4]
- (v) Estimate the voltage drop across 132kV/11kV transformer during the demand condition determined in (iv). [4]

### Question 3

a) Explain briefly why the power flow problem is non-linear?

[2]

b) Active power demand of the 132 kV system shown in Figure below is supplied by two generators G1 and G2. System voltage is supported by generator G2 and a large synchronous compensator SC (see Figure below), which both maintain the voltage at 1 pu at their respective nodes. Generator G1, connected at node 1, has no reactive power capacity available for voltage control.

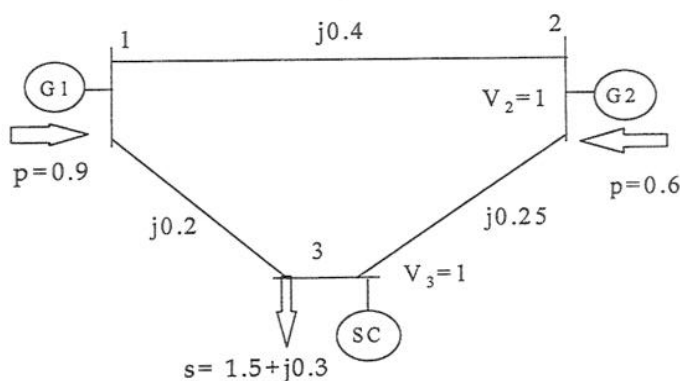

Figure Q3: 132 kV system - all values are in p.u with

- Identify the type of busbars for nodes 1, 2 and 3 (Slack, PV or PQ)
- Form the  $Y_{bus}$  matrix for this system.
- Perform two iterations of the Gauss – Seidel load flow.

[3]

[2]

[13]

#### Question 4

Figure below shows a 66 kV transformer feeder supplying an 11 kV busbar. The load on the busbar B is 12 MW and 5 MVar. The 20 MVA, 66/11 kV transformer has a leakage reactance of 15% on rating and is equipped with an on-load tap changer with tap-steps of 1.25%. The 66 kV overhead line is 30 km long with an impedance of  $0.25+j0.5 \Omega/\text{km}$ . Busbar A is held at 63 kV.

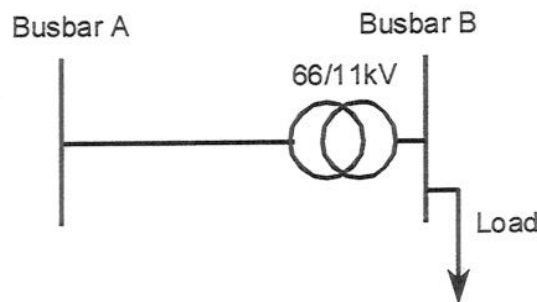

Figure Q4 – The simple power system

- (i) Explain why for determining the exact value of voltage at Busbar B an iterative procedure would be required. Write a non-linear complex equation that links voltages at Busbar A and B. [3]
- (ii) Without carrying out the iterative procedure, calculate an approximate value of the voltage at Busbar B (use a 20 MVA base) [5]
- (iii) Calculate then approximate value of losses in the system [4]
- (iv) Calculate the size of the shunt capacitor bank required at busbar B to bring the voltage to 11 kV [5]
- (v) Explain why losses will reduce after the capacitor bank is installed and calculate this reduction. [3]

### Question 5

Consider a synchronous generator model given in Figure below.

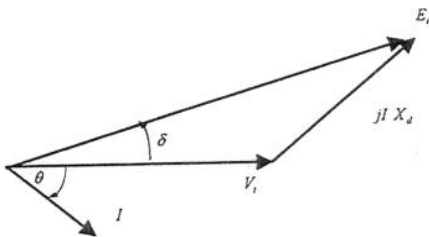
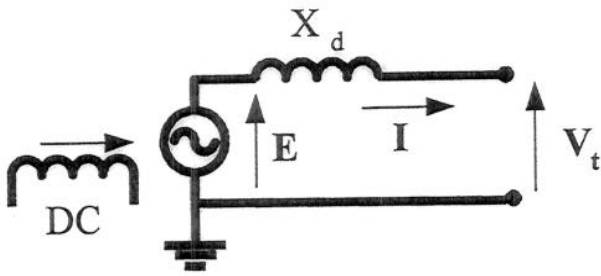

Figure Q5: Single line diagram and corresponding vector diagram of a synchronous generator

- i) Generator is delivering power and a certain angle  $\delta$  exists between the terminal voltage  $V_t$  and the internal voltage of the machine  $E$ . Show that the expressions for active and reactive power are given by:

$$P = \frac{|V_t| |E|}{X_d} \sin \delta$$

$$Q = \frac{|V_t|}{X_d} (|E| \cos \delta - |V_t|)$$

[4]

- ii) Given that the generator is feeding into a very strong network that maintains the voltage at the terminals of the generator and system frequency, what would be the effects of changing (a) excitation voltage and (b) turbine torque?

[4]

iii) The generator parameters are:  $S=150$  MVA,  $P=130$  MW,  $V=11.5$  kV and  $X_d = 1.3$  p.u. on rating,  $E = 2.2$  p.u.max. If the generator operates at 100MW, what is the value of internal voltage at which the generator delivers no reactive power to the system?

[4]

iv) what is the maximum reactive power that the generator can deliver to the system while exporting 100MW?

[4]

v) what is the maximum reactive power that the generator can absorb while delivering 100MW, assuming that the machine angle  $\delta$  due to the stability limits, should not exceed 75 degrees?

[4]

### Question 6

Consider the one-line diagram of a simple power system shown in Figure Q6. System data in per-unit (p.u.) on appropriate MVA base are given as follows:

**Synchronous generators:**

G1:	400 MVA	16 kV	$X_1 = X_2 = 0.15$	$X_0 = 0.05$
G2:	400 MVA	16 kV	$X_1 = X_2 = 0.15$	$X_0 = 0.05$

**Transformers:**

T1:	400 MVA	16/400 kV	$X_1 = X_2 = X_0 = 0.08$
T2:	400 MVA	16/400 kV	$X_1 = X_2 = X_0 = 0.08$

**Transmission lines:**

TL12:	250 MVA	400 kV	$X_1 = X_2 = 0.05$	$X_0 = 0.15$
TL13:	250 MVA	400 kV	$X_1 = X_2 = 0.025$	$X_0 = 0.075$
TL23:	250 MVA	400 kV	$X_1 = X_2 = 0.025$	$X_0 = 0.075$

The neutral of each generator is grounded through a current limiting reactor of 0.03 p.u. on 100 MVA base. All transformer neutrals are solidly grounded. The generators are operating at no-load with a voltage of 1.05 p.u.

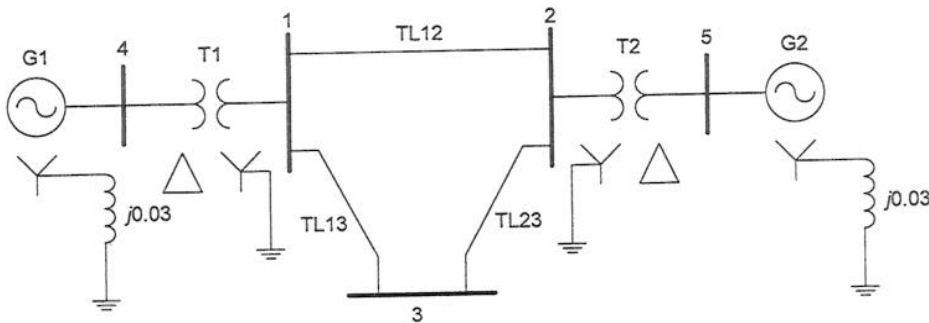

Figure Q6: . A simple power system

(a) Draw the positive, negative and zero sequence networks after expressing all the parameters in 100 MVA base. [5]

(b) Calculate the per unit and absolute value of the current flowing in the fault for a 1-ph to earth fault at busbar 1 [5]

(c) For this condition calculate the current flowing in the faulted phase of the transformers T1 and T2. [10]