

DIGITAL SIGNAL PROCESSING

1. a) State the advantages and disadvantages of polyphase implementations of digital filters in comparison to direct implementations. [3]

- b) Given a filter with system function

$$H(z) = \sum_{k=0}^{N-1} b_k z^{-k},$$

write an equivalent expression for $H(z)$ as a 3-phase type 1 polyphase filter and draw a block diagram of the polyphase implementation. [6]

- c) Consider a 3-phase maximally decimated analysis filter bank.

- i) Draw the block diagram of filter bank employing type 1 polyphase implementation. [6]

- ii) Let $X(z)$ denote the z-transform of the input signal to the filter bank and $Y(z)$ denote the z-transform of the signal corresponding to the filter bank output for the band covering the highest frequencies. Write an expression for $Y(z)$ in terms of $X(z)$ and the lowpass filter prototype $P(z)$. [5]

2. Consider Fourier analysis of a discrete-time signal $x(n)$ using the discrete Fourier transform (DFT).
- a) State and explain what is meant by 'basis functions' in this context. [2]
 - b) In terms of the time index, n , and frequency index, k , write down an expression for the basis functions that would be employed in the Fourier analysis of the sequence $\{x(0), x(1), x(2)\}$ and evaluate these functions over the appropriate range of n and k . [6]
 - c) Given that $X(k)$ is the discrete Fourier transform of $x(n)$, state the conditions on $x(n)$ for $X(k)$ to be real. Support your answer with an illustrative example and show, for your chosen example of $x(n)$, that its Fourier transform is indeed real. [6]
 - d) Consider two real N -point discrete-time signals $p(n)$ and $q(n)$. Show that the two N -point discrete Fourier transforms $P(k)$ and $Q(k)$, of $p(n)$ and $q(n)$ respectively, can be found from a single N -point DFT. [6]

3. Consider a discrete-time linear system with transfer function

$$H(z) = \frac{Y(z)}{X(z)} = \frac{b_0 + b_1z^{-1} + b_2z^{-2}}{1 + a_1z^{-1} + a_2z^{-2}}$$

with input sequence $x(n)$ and output sequence $y(n)$.

- a) i) Write down the difference equation for $y(n)$. [3]
ii) Write an expression for $Y(z)$ explicitly showing that it can be computed using only 2 delay elements. What name is given to this form? Sketch the signal flow diagram corresponding to this form and label it fully. [5]
- b) i) Sketch the signal flow diagram of the system [1]

$$G(z) = \frac{1}{1 - \alpha z^{-1}}$$

- ii) Consider a decomposition of $H(z)$ to the form

$$c_0 + \frac{A_1}{1 - \alpha_1 z^{-1}} + \frac{A_2}{1 - \alpha_2 z^{-1}}$$

Using partial fraction expansion, determine c_0 , α_1 , α_2 , A_1 , and A_2 in terms of b_0 , b_1 , b_2 , a_1 and a_2 . [5]

- iii) Hence construct, sketch and label the signal flow diagram that implements the form of $H(z)$ from part b) (ii). [5]
- iv) Compare the filter structure from part a) (ii) with the filter structure from part b) (iii). [1]

4. a) Consider the function $x(n) = a^n$.
- i) State the significance of the Region of Convergence of the z-transform and, hence, write down the definition of the z-transform of $x(n)$. [3]
 - ii) By considering $x(n)$ as the sum of two one-sided functions, determine the z-transform of each one-sided function and hence show that $x(n) = a^n$ does not have a z-transform. [4]

- b) Using long division, find the inverse z-transform of

$$H(z) = \frac{1 + 1.2z^{-1}}{1 + 0.4z^{-1} - 0.12z^{-2}}$$

Hence determine the first 5 samples of the impulse response of $H(z)$. [7]

- c) Based on the above transfer function, find a causal, stable, IIR equalizer $G(z)$ such that $|H(e^{j\omega})||G(e^{j\omega})| = 1$. [6]

5. a) Write a clear explanation of the method of discrete-time IIR filter design employing the bilinear transform. Explain what is meant by frequency warping in this context. [6]

b) A continuous time 1st-order lowpass filter can be described by the transfer function

$$H_a(s) = \frac{\Omega_c}{s + \Omega_c}$$

where Ω_c is the -3 dB frequency. Show that an equivalent discrete-time transfer function can be obtained using the bilinear transformation as

$$H(z) = \gamma \cdot \frac{1 + z^{-1}}{1 - \alpha z^{-1}}$$

and give expressions for α and γ . [7]

c) Determine α and γ for a -3 dB frequency of 2.4 kHz given that the sampling rate of the input signal is 8000 samples per second. [7]

6. a) Consider the process of zero padding a time domain sequence

$$x(n), \quad n = 0, 1, \dots, N-1$$

in order to obtain a new sequence

$$x_p(n) = \begin{cases} x(n), & 0 \leq n \leq N-1 \\ 0, & N \leq n \leq M-1. \end{cases}$$

- i) Construct and sketch plots of $x(n)$ and $x_p(n)$ for an illustrative example with $N = 4$ and $M = 7$. [4]
 - ii) Give a general expression for $X_p(k)$, the DFT of $x_p(n)$. [4]
 - iii) Now consider the case with $M = NL$ for integer L . Describe the effect seen in the frequency domain of zero padding in the time-domain. State the relationship, if any, between $X_p(k)$ and $X(k)$. [4]
 - iv) Next consider the signal $x(n)$ with modulus of Fourier transform $|X(k)|$ shown in Fig. 6.1. It has been decided to apply zero-padding to $x(n)$ such that the DFT can be computed using an 8-point FFT. For this case, sketch and label the modulus of the Fourier transform of the zero-padded signal. [4]
- b) Consider the process of zero padding the DFT, $X(k)$, of a real sequence $x(n)$ with N points for N odd. Let M be the length of the zero padded DFT and $M = NL$ for integer $L > 0$. Copy and complete the following expression for the zero padded DFT

$$X_p(k) = \begin{cases} X(k), & 0 \leq k \leq \frac{N-1}{2} \\ \vdots \end{cases}$$

such that the inverse DFT of $X_p(k)$ is also real. Comment on a potential use for this technique. [4]

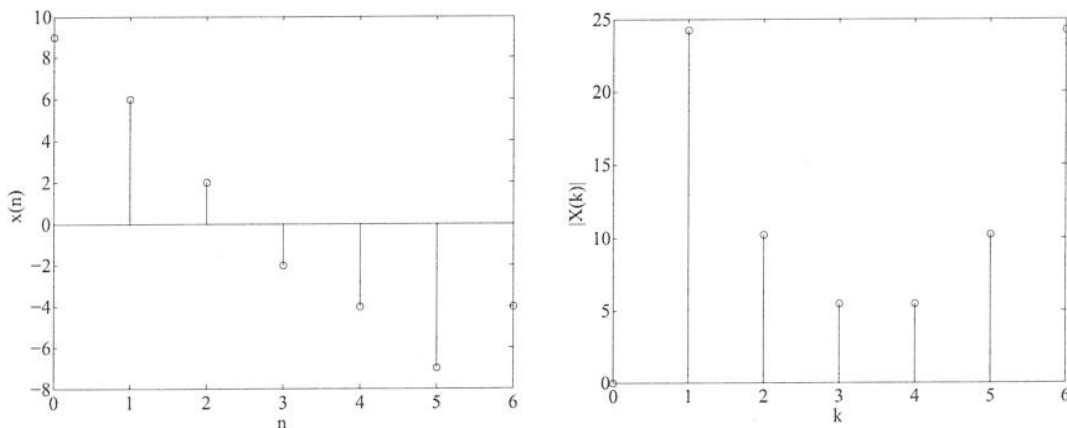

Figure 6.1

DIGITAL SIGNAL PROCESSING
 SOLUTIONS 2009

1. a) Polyphase filtering performs all computations at the lowest possible sampling rate thereby reducing the speed requirements of the processor. Also used in the theoretical study of perfect reconstruction filter banks and other multirate systems
- b)

$$H(z) = \sum_{l=0}^{2} z^{-l} E_l(z^3)$$

$$E_l(z) = \sum_{n=-\infty}^{\infty} e_l(n) z^{-n}$$

$$e_l(n) = b(3n+l) \quad \text{for } 0 \leq l < 3$$

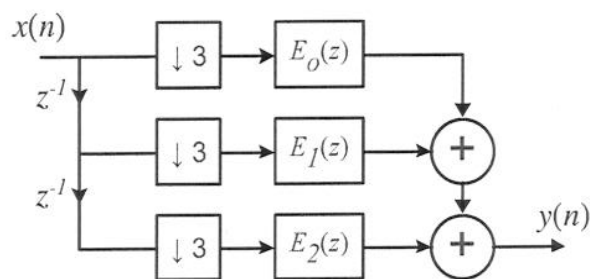

Figure 1.1

- c) 3-phase maximally decimated analysis filter bank (assuming 3 bands but other answers also accepted)
- i) Drawing standard bookwork
- ii)

$$X_k(z) = X(z)H_k(z)$$

$$Y_k(z) = \frac{1}{3} \sum_{l=0}^{2} H_k(z^{1/3}W^l)X(z^{1/3}W^l)$$

where H_k is the k th subband filter and $W = e^{-j2\pi/3}$

The definition of $H_k(z)$ in terms of the prototype $P(z)$ should also be given. Reasonable attempts in terms of modulation will be accepted.

2. a) The basis functions are an orthogonal set of functions from which $x(n)$ can be built as a linear combination. Solution must contain notion of synthesis.
- b) $\exp(-j2\pi kn/3)$

The orthogonal bases for $N = 3$ are:

$$k = 0 \quad [1, 1, 1]$$

$$k = 1 \quad [1, -0.5 - j0.866, -0.5 + j0.866]$$

$$k = 2 \quad [1, -0.5 + j0.866, -0.5 - j0.866]$$

- c) $x(n)$ must have even symmetry such that $x(n) = x(N - n)$.

Example $x(n) = [1 \ 1 \ 1 \ 0 \ 0 \ 1 \ 1]$ gives a real Fourier transform since the imaginary parts associated with $x(1)$ and $x(2)$ are equal but with opposite sign to the imaginary parts associated with $x(7)$ and $x(8)$ respectively.

- d) The properties as followed are required:

$$\text{Re}\{x(n)\} \leftrightarrow \frac{1}{2}(X(k) + X^*(-k))$$

$$j\text{Im}\{x(n)\} \leftrightarrow \frac{1}{2}(X(k) - X^*(-k))$$

from which it can be seen that $x(n)$ can be formed as a complex sequence

$$x(n) = p(n) + jq(n)$$

leading to

$$P(k) = \frac{1}{2}(X(k) + X^*(-k))$$

$$Q(k) = \frac{1}{2j}(X(k) - X^*(-k))$$

3. a) i) The difference equation is given by

$$y(n] = b_0x(n) + b_1x(n-1) + b_2x(n-2) - a_1y(n-1) - a_2y(n-2).$$

- ii) Rearrangement gives

$$Y(z) = b_0X(z) + z^{-1}(b_1X(z) - a_1Y(z) + z^{-1}(b_2X(z) - a_2Y(z))).$$

known as canonical form.

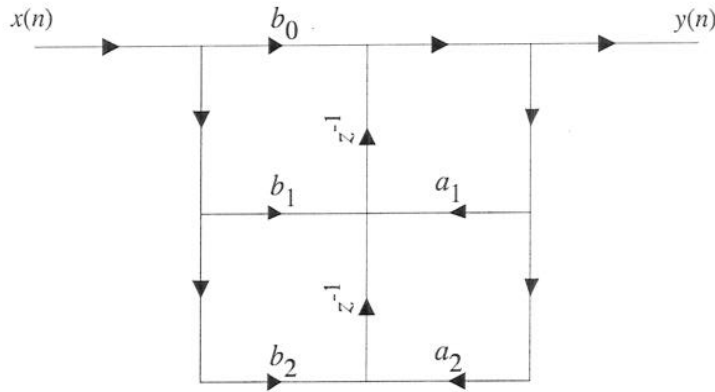

Figure 3.1

- b) i) The first order IIR signal flow diagram:

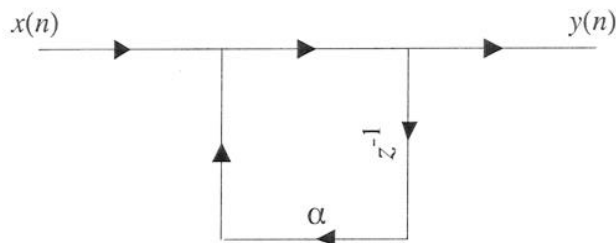

Figure 3.2

- ii) The partial fraction expansion gives:

$$\frac{c_0 + A_1 + A_2 - [c_0(\alpha_1 + \alpha_2) + A_1\alpha_2 + A_2\alpha_1]z^{-1} + c_0\alpha_1\alpha_2z^{-2}}{1 - (\alpha_1 + \alpha_2)z^{-1} + \alpha_1\alpha_2z^{-2}}$$

Comparing terms with $H(z)$ gives the required parameters.

- iii) The signal flow diagram for this (direct) parallel implementation is given in Fig. 3.3
- iv) By way of comparison, both structures use the same quantity of memory; the structure of part b) has better numerical properties because the error feedback is only first order. It is also possible to redraw the structure using only one delay element.

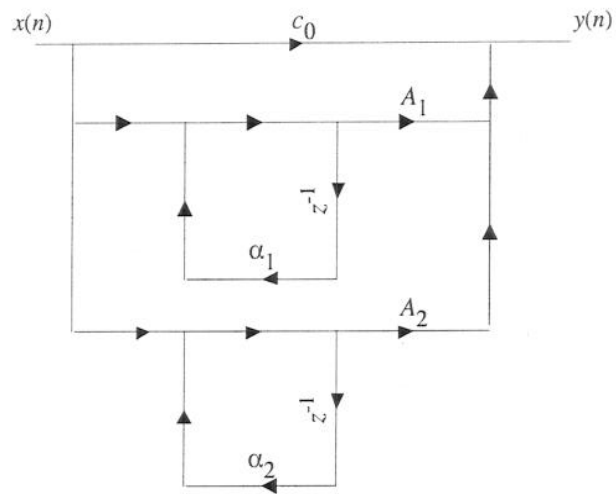

Figure 3.3

4. a) i) The z-transform is expressed as an infinite series. The ROI defines the region of the z-plane for which the z-transform converges.

$$X(z) = \sum_{-\infty}^{\infty} x(n)z^{-n}.$$

- ii) The first term converges for $|z| < |a|$ and the second term converges for $|z| > |a|$. Hence it can be seen that the two ROCs have no common regions.
- b) $H(z) = 1 + 0.8z^{-1} - 0.2z^{-2} + 0.176z^{-3} - 0.094z^{-4}$
- c) To create the equaliser, we could attempt to form $G(z) = H^{-1}(z)$ but the zero at 1.2 will then become an unstable pole. So, first reflect this root inside the unit circle and compensate for the gain:

$$G(z) = 0.832 * \frac{1 + 0.4z^{-1} - 0.12z^{-2}}{1 + 0.83z^{-1}}$$

5. a) The key points to be mentioned are that classical continuous-time filter designs can be used after suitable transformation in discrete-time systems. After the classical continuous-time filter design has been chosen, the two stages of the transformation process are the frequency pre-warping followed by the bilinear transformation. The equations for pre-warping and bilinear transformation should be given.

$$\Omega = \tan(\omega/2)$$

$$s \leftarrow \frac{z-1}{z+1}$$

b)

$$H(z) = \frac{\Omega_c(1+z^{-1})}{(1-z^{-1}) + \Omega_c(1+z^{-1})}$$

with $\alpha = \frac{1-\Omega_c}{1+\Omega_c}$ gives

$$H(z) = \gamma \cdot \frac{1+z^{-1}}{1-\alpha z^{-1}}$$

with $\gamma = \frac{1-\alpha}{2}$.

- c) First step is to pre-warp the -3 dB frequency. For a required -3 dB frequency of 0.3 of the sampling frequency, we obtain

$$\Omega_c = \tan\left(\frac{0.3}{2}2\pi\right) = 1.376$$

so that

$$\alpha = \frac{1-1.376}{1+1.376} = -0.1584$$

and

$$\gamma = \frac{1-\alpha}{2} = 0.5793.$$

6. a) i) Any example comprising 4 non-zero samples followed by 3 zero-valued samples.

ii)

$$X_p(k) = \sum_{n=0}^{N-1} x(n) \exp\left(\frac{-j2\pi kn}{M}\right)$$

iii) The effect of time-domain zero padding can be seen as interpolation in the frequency domain, in this case by a factor L .

The points $X_p(kL)$ of the zero-padded DFT are identical to the corresponding points in $X(k)$, i.e.

$$X_p(kL) = X(k).$$

This is not true unless $M = NL$.

iv) The only requirements of the sketch is that it should show 8 points and none of them should correspond to the values of the $|X(k)|$ except $X(0)$.

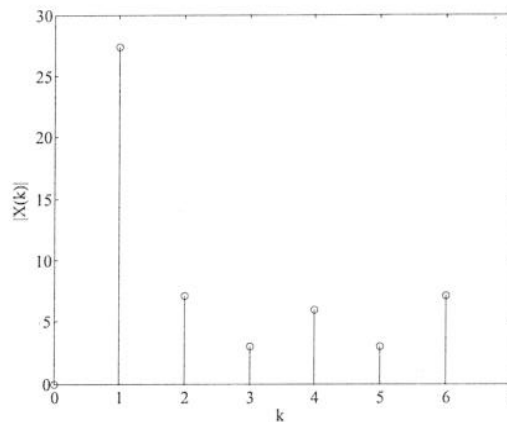

Figure 6.1

b) This could be used as an interpolator given

$$X_p(k) = \begin{cases} X(k), & 0 \leq k \leq \frac{N-1}{2}, \\ X(k-M+N), & M - \frac{N-1}{2} \leq k \leq M-1, \\ 0, & \text{otherwise} \end{cases}$$