

Special instructions for students

Values of some constants:

$$k = 1.38 \times 10^{-23} \text{ J/K}$$

$$e = 1.6 \times 10^{-19} \text{ C}$$

$$c = 3 \times 10^8 \text{ m/s}$$

The Questions

1. In an instrumentation application, an input signal will be sampled and then quantised. The input signal has a constant power spectral density that extends to essentially infinite frequency. The signal contains useful information only at frequencies lower than $f_B < 20 \text{ kHz}$, which needs to be extracted by suitable low pass filtering, sampling and quantisation.
- a) Explain what aliasing is and how it affects a sampled data measurement. Derive a relationship between the frequencies of two sinusoids that are aliases of one another when sampled at a sampling frequency f_s . State the conditions that make possible the exact reconstruction of a sampled signal. [5]
- b) With the aid of a diagram, derive the minimum signal to alias power ratio for this signal over the bandwidth f_B if the signal is filtered with a 1st order low pass filter at a frequency f_F and sampled at a frequency f_s . [5]
- c) Calculate the minimum sampling frequency necessary to sample this signal at 16 bits. The signal is filtered by a first order low pass filter at 30 kHz. What is the necessary minimum order for the anti alias filter if the maximum available sampling rate is 1MHz? [10]

2. A variable power supply needs to be characterised in the laboratory. This power supply is controlled by one input signal, x . The output voltage, y , is empirically modelled as a function of the input x as:

$$y = \frac{A}{1 - \alpha x} + B$$

A set of N measurements $\{y_i, x_i\}$ are performed and recorded.

Set up a set of three linear equations with three unknowns, and any necessary auxiliary equations that can be solved to determine $\{A, B, \alpha\}$ from the measurements.

Do not solve these equations.

[20]

3. A coaxial cable will be used for interconnections in a high frequency measurement system. The cable has a distributed capacitance $c = 100 \text{ pF/m}$ and a distributed inductance $l = 1 \mu\text{H/m}$
- Calculate the characteristic impedance Z_0 of this cable, and the phase velocity c_0 of signals travelling within this cable. Write a formula for the propagation constant for this cable at a given frequency. [2]
 - Write an expression for the input impedance Z_{in} of this cable when the cable is terminated in an impedance Z_T , as shown in Figure 3.1. Calculate the magnitude of Z_{in} if the frequency is such that $\lambda = 8L$. [4]
 - Write an expression for the frequency dependence of Z_{in} if $L = 1 \text{ m}$ and the cable is terminated at $Z_T = 100 \Omega$. [2]
 - Show that there exist frequencies at which $Z_{in} = \infty$ when $Z_T = 0$. Calculate the frequencies $f_{0,m}$ at which this happens. [4]
 - Show that for frequencies a little larger than $f_{0,m}$ from part 3(d) above Z_{in} is capacitive. Calculate the input capacitance of the cable at these frequencies. Express this capacitance in terms of the distributed capacitance of the cable.
HINT: the capacitance is $\frac{d}{d\omega}(\text{Im}(Y))$ [4]
 - Calculate the lowest frequency at which the input impedance of a capacitively terminated line is inductive. Express this frequency in terms of the load capacitance C_T and the distributed inductance of the cable. You may assume that $Z_0 \omega C_T \gg 1$ [4]

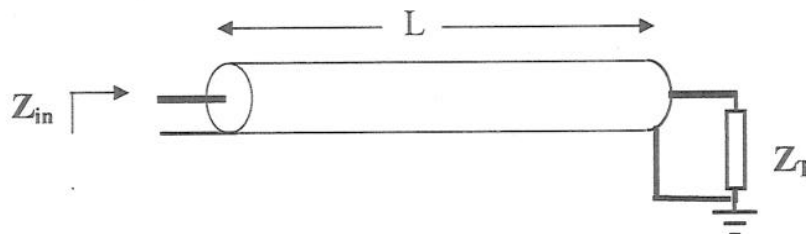

Figure 3.1: Transmission line for problem 3.

4. In an integrated circuit process resistors can be fabricated with values between $10\ \Omega$ and $10\ \text{k}\Omega$. The resistors have actual values that deviate randomly from their nominal values. The maximum deviation is 5%.
- a) Draw a schematic for the binary weighted ladder D/A converter, and write an expression describing its output as a function of its input. Include the effect of resistor tolerances in this equation. [5]
 - b) Calculate the maximum resolution binary-weighted ladder D/A converter that can be manufactured with this integrated circuit process so that the converter can be guaranteed to be monotonic. [5]
 - c) Assuming that the variation in resistance values is completely random. Describe a way to increase the attainable resolution by 1 bit over the value calculated in part 4(b).
HINT: Consider the tolerance of N resistors connected in parallel. [5]
 - d) Draw a schematic of a thermometer coded ladder D/A converter. Explain its operation. List one advantage and one disadvantage of the thermometer coded converter, relative to the binary weighted converter. [5]

5. A DC Wheatstone bridge, shown in Figure 5.1, is used to read a low temperature platinum thermometer. The resistance of the thermometer is given by:

$$R = 10 \text{ k}\Omega + 10(T - 4.2)$$

T is the absolute temperature in Kelvin. The bridge is powered by 1V DC applied between N1 and N2. The thermometer is placed in position Z_4 . The other three components are held at the ambient temperature, nominally 290 K.

- a) Choose component values so that the bridge is balanced at $T = 4.2$ K, and exhibits minimum cross sensitivity to the supply voltage. Calculate the gain of the bridge $G = \frac{\partial V_{34}}{\partial T}$ near $T = 4.2$ K [5]
- b) Calculate the noise of the voltage reading of this bridge. The noise bandwidth is 1 MHz and all resistors apart from the thermometer are at 290 K. What is the resolution of this bridge near the balance temperature? [10]
- c) Let $Z_1 = Z_2 = R_0$ and $Z_3 = 10 \text{ k}\Omega = R_{T0}$. Derive an expression for the resolution of this bridge as a function of $\gamma = R_T / R_{T0}$. From this expression, derive the condition and value for the maximum possible resolution of the bridge. [5]

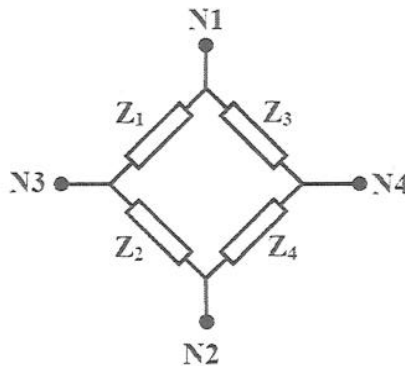

Figure 5.1: A Wheatstone bridge.

6.

- a) Draw a schematic diagram for a fractional PLL synthesiser and describe its operation. Identify all components in your diagram.
Write an expression for the output frequency of the synthesiser as a function of suitable control signals. [5]
- b) Outline the design of a fractional PLL synthesiser for an FM stereo receiver. The following data is given:
- Reference Frequency: 1MHz
 - Output Frequency range: 90-100 MHz
 - Output frequency spacing: 50 kHz
 - Phase detector: Type 1
 - Power supply: 5 V
 - VCO gain: $K_0 = 50 \text{ MHz/V}$
- i) Define the range of values for the feedback path divider. [3]
- ii) Calculate the gain of the phase detector K_d . [2]
- iii) Write an expression for the transfer function of the synthesiser $B(s) = \frac{\varphi_{out}(s)}{\varphi_{in}(s)}$ in terms of the filter transfer function $F(s)$, the divider value D , the VCO gain K_0 and the detector gain K_d . Derive symbolic expressions for the loop bandwidth ω_n and the Quality factor Q if a lead-lag filter is used. [5]
- iv) Calculate the time needed to define an output frequency. This time defines the maximum allowable loop bandwidth of the synthesiser. Define a filter so that the loop bandwidth is 1/5 of this maximum bandwidth and has $Q = 1$. [5]

ANSWERS

2009

The Answers

1.

- a) When two signals generate the same samples when sampled at a sampling frequency f_s we say they are aliases. Frequencies outside the band of interest can be aliases of frequencies within the band. This way off-band signal power can corrupt measurements. Two single tone signals are aliases of each other under f_s if

$$e^{jn\omega_1/f_s} = e^{jn\omega_2/f_s} \quad \forall n \Rightarrow$$

$$n\omega_1 / f_s \text{ mod } 2\pi = n\omega_2 / f_s \text{ mod } 2\pi \Rightarrow \frac{\omega_1 - \omega_2}{\omega_s} = k$$

The Nyquist sampling theorem states that a real signal can be reconstructed if sampled at a frequency larger than twice its bandwidth. This is the direct result of the above equation considering that a real signal contains negative frequencies.

[5]

b)

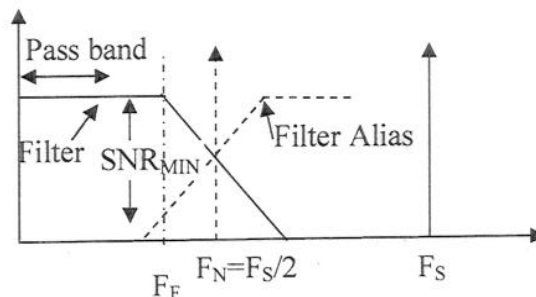

The signal to alias power ratio results from the filter alias line contributing noise-like power to the measurement. According to the diagram, if the filter is a first order LPF, then the alias power at a frequency ω is:

$$P_A = \frac{1}{1 + \left(\frac{\omega_s - \omega}{\omega_F}\right)^2} \text{ so that the signal to alias power ratio is simply: } SAPR = 1 + \left(\frac{\omega_s - \omega}{\omega_F}\right)^2$$

[5]

- c) The minimum SAPR is at the bandwidth, namely:

$$SAPR_{\min} = 1 + \left(\frac{\omega_s - \omega_B}{\omega_F}\right)^2 = 1 + \left(\frac{f_s - f_B}{f_F}\right)^2$$

To sample at 16 bits we need the alias amplitude to be less than $\frac{1}{2}$ LSB.

$$SAPR_{\min} > 2^{34} = 1.72 \times 10^{10} \Rightarrow$$

$$\left(\frac{f_s - f_B}{f_F}\right)^2 \geq 2^{34} = 1.72 \times 10^{10} \Rightarrow \frac{f_s - f_B}{f_F} \geq 1.31 \times 10^5 \Rightarrow$$

$$f_s > 1.31 \times 10^5 f_F = 3.9 \text{ GHz}$$

ANSWERS

This sampling rate is obviously excessive. If the maximum available sampling rate is 1MHz, then

$$\left(\frac{f_s - f_B}{f_F}\right)^{2N} \geq 1.72 \times 10^{10} \Rightarrow 2N \log\left(\frac{10^6}{30 \times 10^3}\right) \geq \log(1.72 \times 10^{10}) \Rightarrow N \geq 3.37$$

which implies that a 4th order filter is required.

[10]

2.

$$y = \frac{A}{1 - \alpha x} + B \Rightarrow (1 - \alpha x)y = A + B(1 - \alpha x) \Rightarrow y = (A + B) - \alpha Bx + \alpha xy = c_1 + c_2x + c_3w$$

where

$$w = xy, c_1 = A + B, c_2 = -\alpha B, c_3 = \alpha$$

Now the linear regression programme can be applied

$$\min_{c_1, c_2, c_3} \sum_i (y_i - c_1 - c_2x_i - c_3w_i)^2 \Rightarrow$$

$$\left. \begin{aligned} \frac{\partial}{\partial c_1} \sum_i (y_i - c_1 - c_2x_i - c_3w_i)^2 = 0 &\Rightarrow \sum_i (y_i - c_1 - c_2x_i - c_3w_i) = 0 \\ \frac{\partial}{\partial c_2} \sum_i (y_i - c_1 - c_2x_i - c_3w_i)^2 = 0 &\Rightarrow \sum_i x_i (y_i - c_1 - c_2x_i - c_3w_i) = 0 \\ \frac{\partial}{\partial c_3} \sum_i (y_i - c_1 - c_2x_i - c_3w_i)^2 = 0 &\Rightarrow \sum_i w_i (y_i - c_1 - c_2x_i - c_3w_i) = 0 \end{aligned} \right\} \Rightarrow$$

$$\sum y_i = Nc_1 + c_2 \sum x_i + c_3 \sum w_i = Nc_1 + c_2 \sum x_i + c_3 \sum x_i y_i \quad (1)$$

$$\sum x_i y_i = c_1 \sum x_i + c_2 \sum x_i^2 + c_3 \sum x_i w_i = c_1 \sum x_i + c_2 \sum x_i^2 + c_3 \sum x_i^2 y_i \quad (2)$$

$$\sum w_i y_i = c_1 \sum w_i + c_2 \sum w_i x_i + c_3 \sum w_i^2 \Rightarrow$$

$$\sum x_i y_i^2 = c_1 \sum x_i y_i + c_2 \sum x_i^2 y_i + c_3 \sum x_i^2 y_i^2 \quad (3)$$

[20]

ANSWERS

3.

$$a) Z_0 = \sqrt{\frac{l}{c}} = 100 \Omega, c_0 = \frac{1}{\sqrt{lc}} = 10^8 \text{ m/s}, k = \frac{\omega}{c_0} = \frac{2\pi f}{c_0} = \frac{2\pi}{\lambda} \quad [2]$$

$$b) Z_m = Z_0 \frac{Z_T + jZ_0 \tan kL}{Z_0 + jZ_T \tan kL}$$

$$\text{at } \lambda = 8L \Rightarrow kL = \frac{\pi}{4} \Rightarrow \tan kL = 1 \Rightarrow Z_m = Z_0 \frac{Z_T + jZ_0}{Z_0 + jZ_T} \Rightarrow |Z_m| = Z_0 \quad [4]$$

$$c) Z_T = Z_0 \Rightarrow Z_m = Z_0 = 100 \Omega \quad [2]$$

$$d) Z_T = 0 \Rightarrow Z_m = Z_0 \frac{jZ_0 \tan kL}{Z_0} = jZ_0 \tan kL$$

Z_T becomes infinite when

$$kL = n\pi + \frac{\pi}{2} \Rightarrow \frac{2\pi f_{0,n}}{c_0} L = \frac{(2n+1)\pi}{2} \Rightarrow f_{0,n} = \frac{(2n+1)c_0}{4L} = (25 + 50n) \text{ MHz} \quad [4]$$

e) near such a resonance,

$$f = f_n + \delta f \Rightarrow kL = n\pi + \frac{\pi}{2} + \frac{2\pi\delta f}{c_0} L \Rightarrow \tan kL = -\cot\left(\frac{2\pi\delta f}{c_0} L\right) \approx \frac{-c_0}{2\pi L\delta f}$$

$$Y_m = \frac{1}{jZ_0 \tan(kL)} = \frac{j}{Z_0} \frac{2\pi L\delta f}{c_0}$$

This is indeed capacitive, with a capacitance equal to $C_{\text{eff}} = \frac{L}{Z_0 c_0} = Lc$, which equals the total distributed capacitance of the cable. [4]

$$e) \text{ we require that: } \text{Im } Z_m > 0 \Rightarrow \frac{\omega C Z_0 \tan kL - 1}{\omega C Z_0 + \tan kL} > 0 \Rightarrow \tan kL > \frac{1}{\omega C Z_0} \Rightarrow \frac{\omega}{c_0} L > \frac{1}{\omega C Z_0} \Rightarrow$$

$$\Rightarrow \omega^2 L > \frac{c_0}{C^2 Z_0} = \frac{1}{\sqrt{lc}} \frac{1}{C^2} \sqrt{\frac{c}{l}} \Rightarrow \omega^2 > \frac{1}{CLl}$$

This is the frequency at which the cable distributed inductance resonates the terminating capacitor. We also need

$$\frac{d}{d\omega} \text{Im } Z_m > 0 \Rightarrow \frac{d}{d\omega} \frac{\omega C Z_0 \tan kL - 1}{\omega C Z_0 + \tan kL} > 0 \Rightarrow \frac{d}{d\varphi} \frac{\alpha \tan \varphi - 1}{\alpha + \tan \varphi} > 0, \alpha = \omega C Z_0, \varphi = kL$$

$$\Rightarrow \frac{(\alpha + \tan \varphi) \alpha \sec^2 \varphi - (\alpha \tan \varphi - 1) \sec^2 \varphi}{(\alpha + \tan \varphi)^2} > 0 \Rightarrow \frac{(\alpha^2 + 1) \sec^2 \varphi}{(\alpha + \tan \varphi)^2} > 0$$

Which is always true. [4]

ANSWERS

4. a)

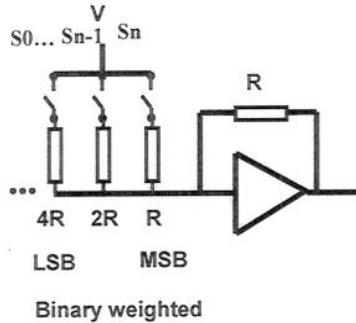

$$V_{out} = -\sum \frac{S_n}{2^n (1 + \delta_n)} \quad [5]$$

b) The limit of monotonicity is when the error in the MSB contributes more than $\frac{1}{2}$ an LSB.

$$G = 1/R \Rightarrow$$

$$|\delta G_N| = \left| \frac{1}{2} \delta G_0 \right| \Rightarrow \frac{\delta}{R^2} \geq \frac{1}{2} \frac{1}{2^N R} \Rightarrow 2^{N+1} \geq \frac{R}{\delta} = 20 \Rightarrow N > 3$$

Therefore converters only up to 3 bits can be expected to be monotonic.

[5]

c) The tolerance of a resistor value will be reduced by a factor \sqrt{N} if N separate resistors are used to make it. Therefore, since it is the MSB that has excessive tolerance, an additional bit can be obtained by reducing the tolerance of the MSB by a factor of 2, by connecting four resistors of value $4R$ in parallel to make the MSB resistor.

[5]

d) The answer in part c taken to its extreme constitutes the thermometer coded converter:

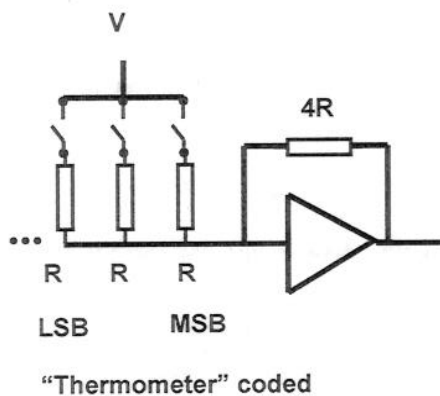

In this converter the N th bit is represented by closing 2^N switches. One advantage is minimum tolerances. One disadvantage is the large chip area required. The performance of the thermometer coded converter can be improved by randomly shuffling the switches representing any particular bit.

[5]

ANSWERS

5. a)

$$Z_3 = Z_4 = R_{T0}, \quad Z_1 = Z_2 = R_0, \quad R_{T0} = 10k\Omega$$

$$V_{34} = V_s \left(\frac{R_2}{R_1 + R_2} - \frac{R_4}{R_3 + R_4} \right) = V_s \left(\frac{1}{2} - \frac{R_{T0} + \alpha(T - T_0)}{2R_{T0} + \alpha T} \right) \Rightarrow$$

$$G = \frac{\partial V_{34}}{\partial T} = -\frac{V_s}{2} \frac{\partial}{\partial T} \left(\frac{1 + \alpha(T - T_0)/R_{T0}}{1 + \alpha(T - T_0)/2R_{T0}} \right) \approx -\frac{V_s}{2} \frac{\partial}{\partial T} (1 + \alpha(T - T_0)/2R_{T0}) = -\frac{\alpha V_s}{4R_{T0}} =$$

$$= \frac{-10}{40000} = -250 \mu V / K$$

[5]

b) The noise source of the left half circuit is two Johnson circuits R_0 connected in parallel, so the total noise is that of a resistor of value $R_0/2$

$$\text{i.e. } V_{N12} = \sqrt{2kTR_0B} = 8.95 \mu V \text{ RMS}$$

$$R_T = R_0/2$$

The noise circuit of the right half circuit is one Johnson circuit R_{T0} connected in parallel with a noiseless R_{T0} . If $R_0 = R_{T0}$

$$V_{N34} = \sqrt{kTR_{T0}B} = 6.33 \mu V \text{ RMS}$$

$$R_T = R_{T0}/2$$

The total noise of the bridge is:

$$V_N^2 = V_{N12}^2 \left(\frac{R_{T0}}{R_0 + R_{T0}} \right)^2 + V_{N34}^2 \left(\frac{R_0}{R_0 + R_{T0}} \right)^2 = \frac{3}{2} V_{N12}^2 \frac{1}{4} \Rightarrow V_N = \sqrt{\frac{3}{8}} V_{N12} = 5.48 \mu V$$

$$\text{The resolution of the bridge is } \delta T = \frac{5.48 \mu V}{250 \mu V} = 0.022 K$$

[10]

c)

$$V_N^2 = V_{N12}^2 \left(\frac{R_{T0}}{R_0 + R_{T0}} \right)^2 + V_{N34}^2 \left(\frac{R_0}{R_0 + R_{T0}} \right)^2 = 4kTB \left(\left(\frac{\sqrt{2R_0 R_{T0}}}{R_0 + R_{T0}} \right)^2 + \left(\frac{\sqrt{R_{T0} R_0}}{R_0 + R_{T0}} \right)^2 \right) =$$

$$= \frac{4kTB R_0 R_{T0}}{R_0 + R_{T0}} \left(\frac{2R_{T0}}{R_0 + R_{T0}} + \frac{R_0}{R_0 + R_{T0}} \right) = 4kTB R_{T0} \frac{\gamma(2+\gamma)}{(1+\gamma)^2}, \quad \gamma = \frac{R_0}{R_{T0}}$$

$$\frac{d}{d\gamma} \frac{\gamma(2+\gamma)}{(1+\gamma)^2} = \frac{2(1+\gamma)(1+\gamma)^2 - 2(2+\gamma)(1+\gamma)}{(1+\gamma)^4} = 2 \frac{(1+\gamma)^2 - (2+\gamma)}{(1+\gamma)^3} = 2 \frac{\gamma-1}{(1+\gamma)^2}$$

The noise of the bridge, is minimum at $\gamma = 1$ where the resolution is maximum.

[5]

ANSWERS

6. a)

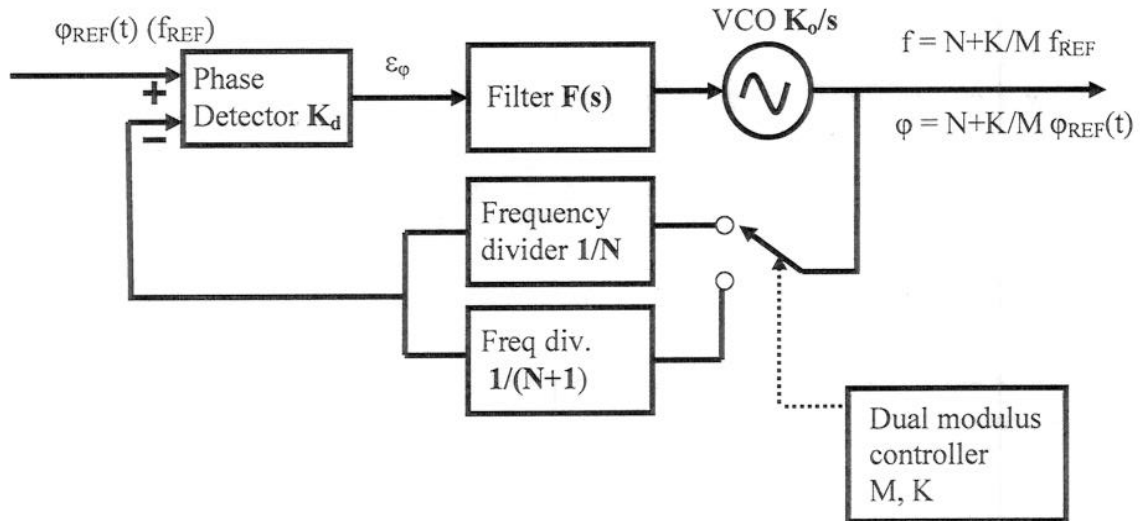

The dual modulus controller alternates the divider between the values N and $N+1$ so that it spends K cycles dividing by $N+1$ and $M-K$ cycles dividing by N .

The output frequency is

$$f_0 = f_{REF} \left(\frac{K(N+1) + (M-K)N}{M} \right) = f_{REF} (N + K/M)$$

[5]

b) i) The feedback divider needs to have $90 < N < 100$ and $M=20$

[3]

ii) The type 2 detector has a gain $K_d = \frac{V}{\pi}$

[2]

iii)
$$B(s) = \frac{\phi_{out}}{\phi_{in}} = \frac{K_d K_o F(s)}{s + K_d K_o F(s)/N} = \frac{NKF(s)}{s + KF(s)}$$

where $K = K_d K_o / N = 2\pi \times 50 \times 10^6 \times \frac{1}{100\pi} = 10^6 \text{ s}^{-1}$

if F a lead-lag, $F(s) = \frac{1 + \tau_2 s}{1 + \tau_1 s}$

With this filter, the PLL loop transfer function becomes:

$$B(s) = N \frac{K(1 + \tau_2 s)}{s(1 + \tau_1 s) + K(1 + \tau_2 s)} = N \frac{s\omega_n(2\zeta - \omega_n/K) + \omega_n^2}{s^2 + 2s\zeta\omega_n + \omega_n^2}$$

with the natural frequency and damping factor given by:

ANSWERS

$$\omega_n = \sqrt{\frac{K}{\tau_1}} \Rightarrow K = \omega_n^2 \tau_1, \quad 2\zeta = \frac{1}{Q} = \sqrt{\frac{1}{\tau_1 K}} (1 + \tau_2 K) \Rightarrow$$

$$Q = \frac{\omega_n \tau_1}{1 + \omega_n^2 \tau_1 \tau_2} = \frac{1}{\frac{1}{\omega_n \tau_1} + \omega_n \tau_2}$$

[5]

iv) To define the output frequency a minimum of MN output periods are needed, or M input periods. With the numbers given this is $\Delta t = 20 \mu s$, and the max bandwidth is 50kHz. According to the instructions the natural frequency

$$\omega_n = \sqrt{\frac{K}{\tau_1}} = 2\pi \times 10^4 s^{-1} = \sqrt{\frac{10^6}{\tau_1}} \Rightarrow \tau_1 = \frac{10^{-2}}{4\pi^2} = 63 \mu s \Rightarrow$$

$$\omega_n \tau_1 = 2\pi \times 10^3 \frac{10^{-2}}{4\pi^2} = 1.59$$

$$Q = \frac{1}{\frac{1}{\omega_n \tau_1} + \omega_n \tau_2} \Rightarrow 1 = \frac{1}{0.628 + \omega_n \tau_2} \Rightarrow \omega_n \tau_2 = .372 \Rightarrow \tau_2 = 5.92 \mu s$$

[5]

