

Special instructions for invigilators: None

Information for candidates: None

[Question 1 is compulsory]

1. a) Briefly describe the following classes of systems: i) a causal system; ii) a time invariant system.

A system has the following time-domain input-output relation.

$$y(t) = x(t) - 0.5 \times x(t+1)$$

State with justification, whether this system is time-invariant and causal.

[4]

- b) Separate the signal shown in Figure 1.1 into its even and odd components, and provide rough sketches for each component.

[4]

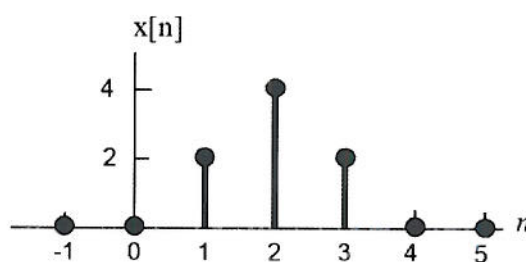

Figure 1.1

- c) Find the first derivatives of the following signals and sketch the signals and their derivatives.

i) $x(t) = u(t) - u(t - a), \quad a > 0$

[2]

ii) $y(t) = t \times [u(t) - u(t - a)], \quad a > 0.$

[2]

- d) For the circuit shown in Figure 1.2, find the differential equations relating the loop currents $y_1(t)$ and $y_2(t)$ to the input $f(t)$.

[5]

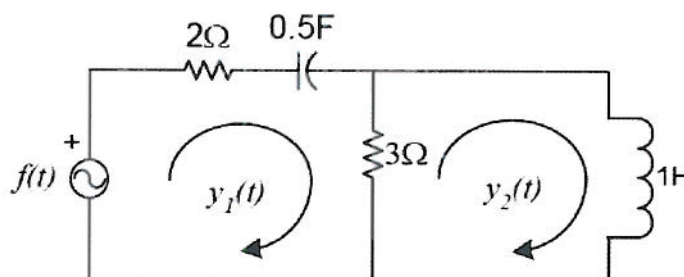

Figure 1.2

- e) Find the impulse response $h(t)$ of a continuous-time LTI system with the input-output relation given by:

$$y(t) = \int_{-\infty}^t e^{-(t-\tau)} x(\tau) d\tau.$$

[4]

- f) Let $h(t)$ be the triangular signal shown in Figure 1.3(a) and let $x(t)$ be a train of unit impulses shown in Figure 1.3(b) and expressed as

$$x(t) = \delta_T(t) = \sum_{n=-\infty}^{\infty} \delta(t - nT).$$

Use the graphical method to sketch $y(t) = h(t) * x(t)$ for the following values of T :

- i) $T = 3$,
- ii) $T = 1.5$.

[4]

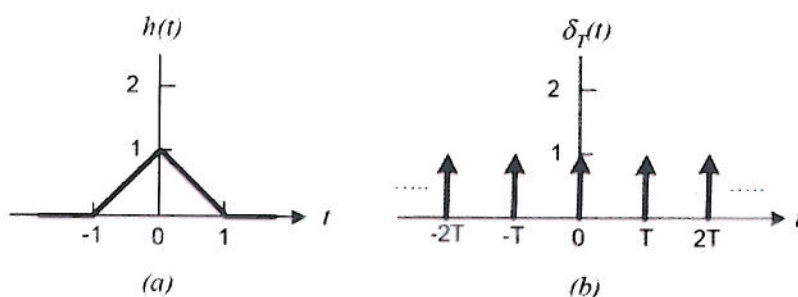

Figure 1.3

- g) Derive the transfer function of a continuous-time LTI system with poles at $s = 0.2 \pm 1.5j$, and zeros at $s = \pm 1.5j$. Sketch the frequency response of this system.

[4]

- h) Find, from first principle, the Fourier transform of the signal

$$x(t) = e^{-a|t|} = \begin{cases} e^{-at} & t > 0 \\ e^{at} & t < 0 \end{cases}.$$

[4]

- i) Using the z -transform pair $\gamma^k u[k] \Leftrightarrow \frac{z}{z - \gamma}$, or otherwise, find the z -transform $X(z)$ of the sequence:

$$x[n] = \left(\frac{1}{2}\right)^n u[n] + \left(\frac{1}{3}\right)^n u[n].$$

[4]

- j) An audio compact disc (CD) stores music digitally as 16-bit numbers at a rate of 44.1k samples per second.

- i) Assuming that reconstruction of the analogue signal is using a non-ideal low-pass filter, state with justifications the maximum frequency that can be stored.

[2]

- ii) What data rate is expected to be read from this audio CD?

[1]

2. For the circuit shown in Figure 2.1, the voltages on capacitors C_1 and C_2 are 1V and 2V respectively after both switches have been opened for a long time. The two switches are then closed simultaneously at $t = 0$.

a) Given the Laplace transform pair $e^{-\lambda}u(t) \Leftrightarrow \frac{1}{s+\lambda}$, find the currents $i_1(t)$ and $i_2(t)$ for $t \geq 0$.

[15]

b) By applying the initial value theorem, or otherwise, find the voltages across the capacitors C_1 and C_2 at $t = 0+$ (i.e. the initial values on the capacitors immediately after the switches are closed).

[15]

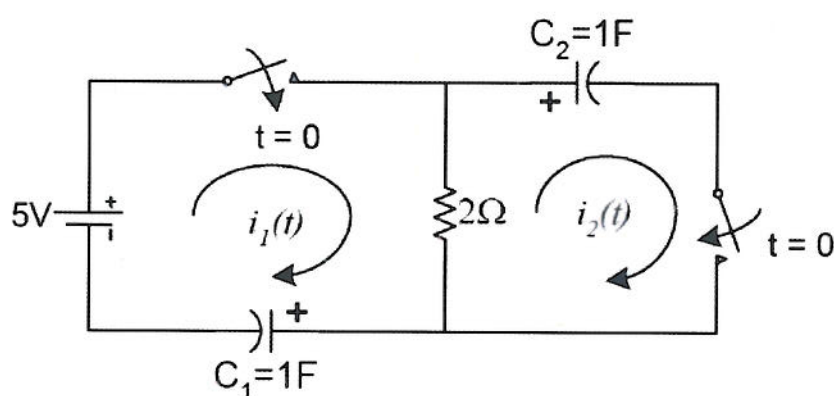

Figure 2.1

3. a) Given that the Fourier transform of $x(t)$ is $X(\omega)$, the differentiation property of the Fourier transform states that:

$$\frac{dx(t)}{dt} \Leftrightarrow j\omega \times X(\omega).$$

The signum function, $\text{sgn}(t)$, is defined as:

$$\text{sgn}(t) = \begin{cases} +1 & t > 0 \\ -1 & t < 0 \end{cases}.$$

- i) Express the $\text{sgn}(t)$ function in terms of the step function $u(t)$.

[6]

- ii) By applying the differentiation property, or otherwise, show that the Fourier transform of $\text{sgn}(t)$ is:

$$\text{sgn}(t) \Leftrightarrow \frac{2}{j\omega}.$$

[12]

- b) Given the Fourier transform pair:

$$e^{-at}u(t) \Leftrightarrow \frac{1}{a + j\omega},$$

using the definition of the time-domain convolution theorem, show that the inverse Fourier transform of $X(\omega) = \frac{1}{(a + j\omega)^2}$ is $te^{-at}u(t)$.

[12]

4. A discrete-time LTI system with a sampling frequency of 8kHz is shown in Figure 4.1. The rectangular boxes with the label z^{-1} provide one sample period delay to their input signals. The circular components are adders or subtractors. The triangular components provide constant gain factors of a_i or b_i , where i is 0, 1 or 2.

- a) Derive the system transfer function $H(z)$.

[10]

- b) Find the difference equation relating the output $y[n]$ and input $x[n]$.

[5]

- c) The gain values for this system are:

$$b_0 = 1, b_1 = -2/\sqrt{2}, b_2 = 1$$

$$a_1 = -1.8/\sqrt{2}, a_2 = 0.9^2.$$

Find the poles and zeros of the system.

[10]

- d) Sketch the frequency response of the system.

[5]

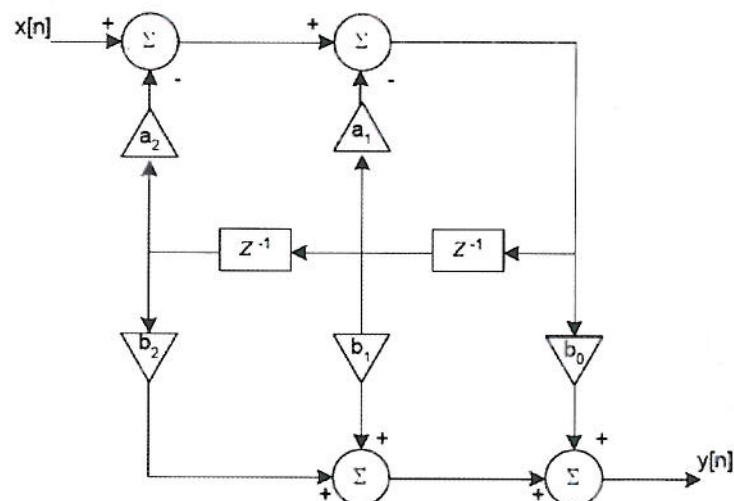

Figure 4.1

[THE END]

**E2.5 Signals and Linear Systems
Solutions 2010**

All questions are unseen.

Question 1 is compulsory.

Answer to Question 1

a)

- i) A system is causal if its output $y(t)$ at an arbitrary time $t = t_0$ depends on only the input $x(t)$ for $t \leq t_0$.
- ii) A system is time-invariant if a time shift in the input signal causes the same time shift in the output signal, i.e.

$$\text{if } y(t) = H(x(t)), \text{ then } y(t - \tau) = H(x(t - \tau)).$$

The system is non-causal because the present output depends on future inputs. It is time-invariant:

$$x(t + \tau) - 0.5x(t + \tau + 1) = y(t + \tau).$$

[4]

b)

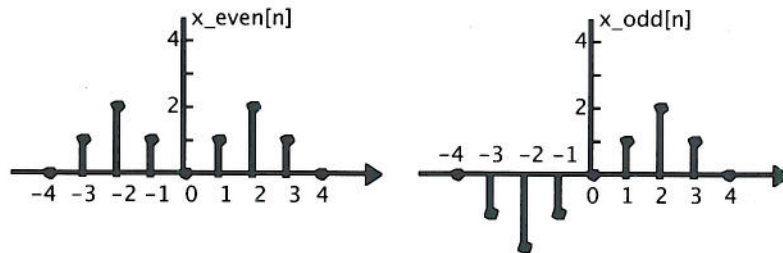

[4]

- c) i) $x(t) = u(t) - u(t - a), \quad a > 0$

$$u'(t) = \delta(t) \quad \text{and} \quad u'(t - a) = \delta(t - a)$$

$$x'(t) = u'(t) - u'(t - a) = \delta(t) - \delta(t - a)$$

- ii) $y(t) = t \times [u(t) - u(t - a)], \quad a > 0$

$$x'(t) = [u(t) - u(t - a)] + t[\delta(t) - \delta(t - a)]$$

But $t\delta(t) = (0)\delta(t) = 0$ and $t\delta(t - a) = a\delta(t - a)$.

Therefore

$$x'(t) = u(t) - u(t - a) - a\delta(t - a).$$

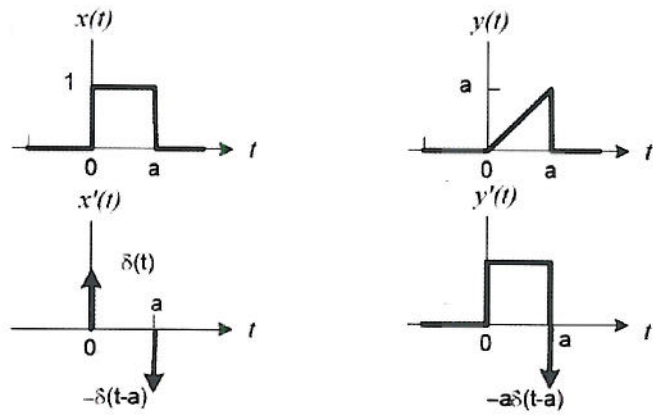

[4]

d)

The loop equations for the circuit are:

$$\begin{pmatrix} 5 + \frac{2}{D} & -3 \\ -3 & D + 3 \end{pmatrix} \begin{bmatrix} y_1(t) \\ y_2(t) \end{bmatrix} = \begin{bmatrix} f(t) \\ 0 \end{bmatrix}$$

Applying the Cramer's rule gives:

$$y_1(t) = \frac{D(D+3)}{5D^2 + 8D + 6} f(t) \quad \text{and} \quad y_2(t) = \frac{3D}{5D^2 + 8D + 6} f(t).$$

[5]

e) $y(t) = \int_{-\infty}^t e^{-(t-\tau)} x(\tau) d\tau$

$$h(t) = \int_{-\infty}^t e^{-(t-\tau)} \delta(\tau) d\tau = e^{-(t-\tau)} \Big|_{\tau=0} = e^{-t}, \quad t > 0$$

Thus, $h(t) = e^{-t} u(t)$.

[4]

f)

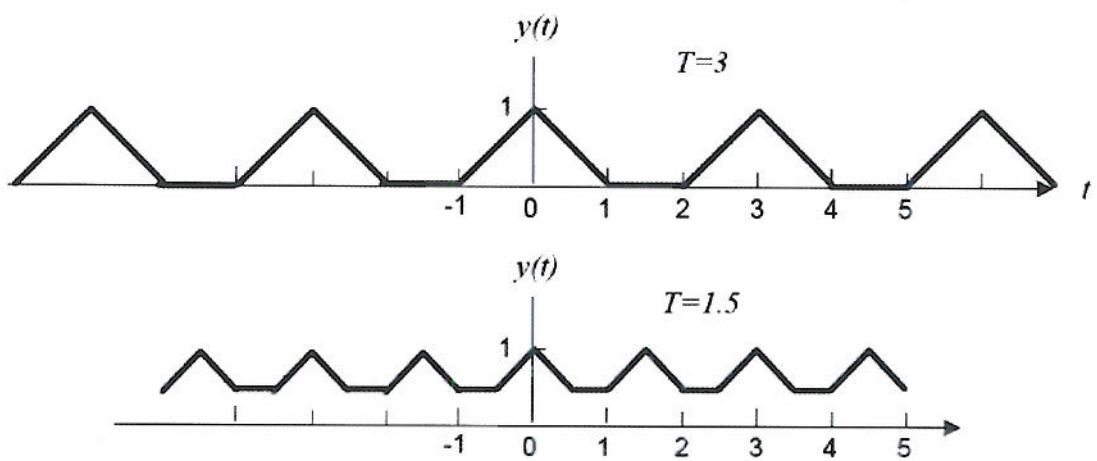

[4]

g)

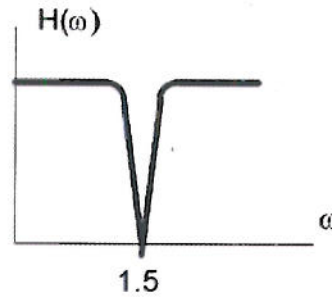

$$H(s) = \frac{s^2 + 2.25}{s^2 + 0.4s + 2.29}$$

[4]

h)

$$\begin{aligned} X(\omega) &= \int_{-\infty}^0 e^{at} e^{-j\omega t} dt + \int_0^{\infty} e^{-at} e^{-j\omega t} dt \\ &= \int_{-\infty}^0 e^{(a-j\omega)t} dt + \int_0^{\infty} e^{-(a+j\omega)t} dt \\ &= \frac{1}{a-j\omega} + \frac{1}{a+j\omega} = \frac{2a}{a^2 + \omega^2} \end{aligned}$$

[4]

i)

$$\left(\frac{1}{2}\right)^n u[n] \Leftrightarrow \frac{z}{z - 1/2}$$

$$\left(\frac{1}{3}\right)^n u[n] \Leftrightarrow \frac{z}{z - 1/3}$$

$$X(z) = \frac{z}{z - 1/2} + \frac{z}{z - 1/3} = \frac{2z\left(z - \frac{5}{12}\right)}{\left(z - \frac{1}{2}\right)\left(z - \frac{1}{3}\right)}$$

[4]

j)

i) Nyquist Sampling theorem dictates that the maximum signal frequency is $0.5 \times 44.1 \text{ kHz} = 22.05 \text{ kHz}$. Since a non-ideal filter is used for reconstruction, assume that the anti-aliasing filter is designed to cut out everything up to 80% this theoretical maximum. Therefore maximum frequency of signal is 17.64 kHz.

[2]

ii) Data rate is:

$$44.1 \times 10^3 \times 16 = 1,411,200 \text{ bits per second .}$$

[1]

Answer to Question 2

a) From the initial conditions, we have:

$$v_{C1}(0^-) = 1V \quad \text{and} \quad v_{C2}(0^-) = 2V$$

Construct a transformed circuit in the s-domain:

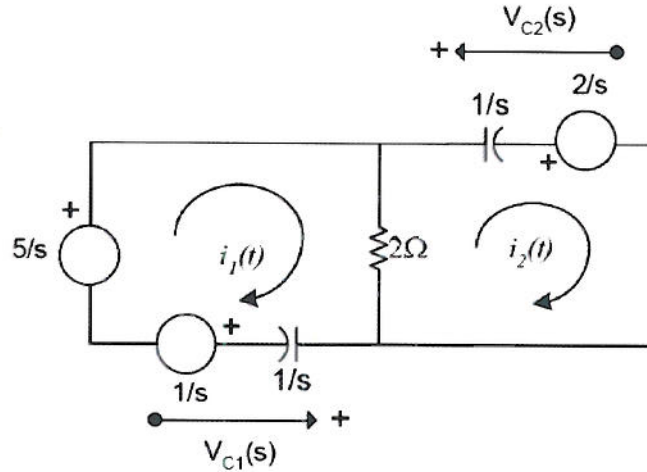

The loop equation is therefore:

$$\begin{aligned} \left(2 + \frac{1}{s}\right)I_1(s) - 2I_2(s) &= \frac{4}{s} \\ -2I_1(s) + \left(2 + \frac{1}{s}\right)I_2(s) &= -\frac{2}{s} \end{aligned}$$

Solving for $I_1(s)$ and $I_2(s)$ yields:

$$\begin{aligned} I_1(s) &= \frac{s+1}{s+\frac{1}{4}} = \frac{s+\frac{1}{4}+\frac{3}{4}}{s+\frac{1}{4}} = 1 + \frac{3}{4}\left(\frac{1}{s+\frac{1}{4}}\right) \\ I_2(s) &= \frac{s-\frac{1}{2}}{s+\frac{1}{4}} = \frac{s+\frac{1}{4}-\frac{3}{4}}{s+\frac{1}{4}} = 1 - \frac{3}{4}\left(\frac{1}{s+\frac{1}{4}}\right) \end{aligned}$$

Taking the inverse Laplace transforms of $I_1(s)$ and $I_2(s)$:

$$\begin{aligned} i_1(t) &= \delta(t) + \frac{3}{4}e^{-t/4}u(t) \\ i_2(t) &= \delta(t) - \frac{3}{4}e^{-t/4}u(t) \end{aligned}$$

[15]

b) From the transformed equivalent circuit above, we get:

$$V_{C1}(s) = \frac{1}{s}I_1(s) + \frac{1}{s}$$

$$V_{C2}(s) = \frac{1}{s}I_2(s) + \frac{2}{s}$$

Substituting the results from part (a) for $I_1(s)$ and $I_2(s)$ yields:

$$V_{C1}(s) = \frac{1}{s} \left(\frac{s+1}{s+\frac{1}{4}} \right) + \frac{1}{s}$$

$$V_{C2}(s) = \frac{1}{s} \left(\frac{s-\frac{1}{2}}{s+\frac{1}{4}} \right) + \frac{2}{s}$$

Apply the initial value theorem, we get:

$$V_{C1}(0^+) = \lim_{s \rightarrow \infty} sV_{C1}(s) = \lim_{s \rightarrow \infty} \frac{s+1}{s+\frac{1}{4}} + 1 = 1 + 1 = 2V$$

$$V_{C2}(0^+) = \lim_{s \rightarrow \infty} sV_{C2}(s) = \lim_{s \rightarrow \infty} \frac{s-\frac{1}{2}}{s+\frac{1}{4}} + 2 = 1 + 2 = 3V$$

[15]

Answer to Question 3

a) i) The signum function $\text{sgn}(t)$ can be expressed as:

$$\text{sgn}(t) = 2u(t) - 1 \quad [10]$$

ii) Therefore $\frac{d}{dt}\text{sgn}(t) = 2\delta(t)$.

$$\text{Let } \text{sgn}(t) \Leftrightarrow X(\omega).$$

We have:

$$j\omega \times X(\omega) = FT [2\delta(t)] = 2,$$

Hence

$$\text{sgn}(t) \Leftrightarrow \frac{2}{j\omega}. \quad [10]$$

b)

$$X(\omega) = \frac{1}{(a + j\omega)^2} = \left(\frac{1}{a + j\omega}\right) \times \left(\frac{1}{a + j\omega}\right)$$

The time convolution theorem states that multiplication in the frequency domain is equivalent to convolution in the time domain. That is:

$$x_1(t) * x_2(t) \Leftrightarrow X_1(\omega) \times X_2(\omega).$$

Given that:

$$e^{-at}u(t) \Leftrightarrow \frac{1}{a + j\omega},$$

we get:

$$\begin{aligned} x(t) &= e^{-at}u(t) * e^{-at}u(t) \\ &= \int_{-\infty}^{\infty} e^{-a\tau}u(\tau) e^{-a(t-\tau)}u(t-\tau)d\tau \\ &= e^{-at} \int_0^t d\tau = te^{-at}u(t). \end{aligned}$$

Hence:

$$te^{-at}u(t) \Leftrightarrow \frac{1}{(a + j\omega)^2}. \quad [10]$$

Answer to Question 4

a) $H(z) = \frac{b_0 + b_1z^{-1} + b_2z^{-2}}{1 + a_1z^{-1} + a_2z^{-2}}$ [10]

b) $y[n] = b_0x[n] + b_1x[n-1] + b_2x[n-2] - a_1y[n-1] + a_2y[n-2]$ [5]

c) $H(z) = \frac{1 - \frac{2}{\sqrt{2}}z^{-1} + z^{-2}}{1 - \frac{1.8}{\sqrt{2}}z^{-1} + 0.9^2z^{-2}}$

Factorize numerator and denominator polynomial gives:

zeros at $\frac{1}{\sqrt{2}} \pm \frac{1}{\sqrt{2}}j$.

poles at $0.9 \times \left(\frac{1}{\sqrt{2}} \pm \frac{1}{\sqrt{2}}j \right)$.

[10]

d) This is a notch filter with poles and zeros as shown:

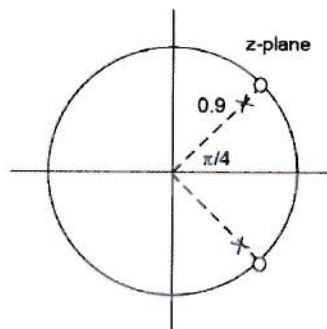

The notch frequency is at $1/8 \times$ sampling frequency = 1kHz.

[5]