

Q1. All taught.

a) 10 ohm (the amp is unilateral, the input impedance does not depend on the load). [4]

$$b) h_{11} = \left. \frac{\partial v_1}{\partial i_1} \right|_{v_2=0} \quad [\Omega], \quad h_{12} = \left. \frac{\partial v_1}{\partial v_2} \right|_{i_1=0} \quad [\#], \quad h_{21} = \left. \frac{\partial i_2}{\partial i_1} \right|_{v_2=0} \quad [\#], \quad h_{22} = \left. \frac{\partial i_2}{\partial v_2} \right|_{i_1=0} \quad [S] \quad [4]$$

c) Q is the inverse of twice the damping factor, the coefficient of the linear term of the denominator of the transfer function. If $Q > 1$ the transfer function peaks near the break frequency, the peak width being Q times smaller than the break frequency. $Q \gg 1$ means that the filter "rings" [4]

d)

$$H(s) = \frac{H_0 s^2}{s^2 + \omega_0 s / Q + \omega_0^2} = \frac{H_0 s^2 / \omega_0^2}{s^2 / \omega_0^2 + 2\zeta s / \omega_0 + 1}$$

H_0 is the maximum amplitude, ω_0 is the break frequency, ζ is the damping factor, Q is the quality factor [4]

e) An op-amp is an ideal voltage amplifier with infinite voltage gain. The op-amp is also a difference amplifier, having both inverting and non-inverting inputs. [4]

f)

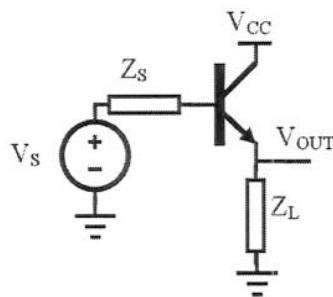

The Common Collector Amplifier has large input impedance, equal to the load impedance multiplied by the current gain of the transistor, and small output impedance equal to the inverse of the transconductance. Also called the emitter follower, it is a unity gain voltage amplifier, and G parameters are the most appropriate to describe it. It is used as a power amplifier.

g) H is a current amplifier. The two circuits are equivalent only in terms of input and output impedances.

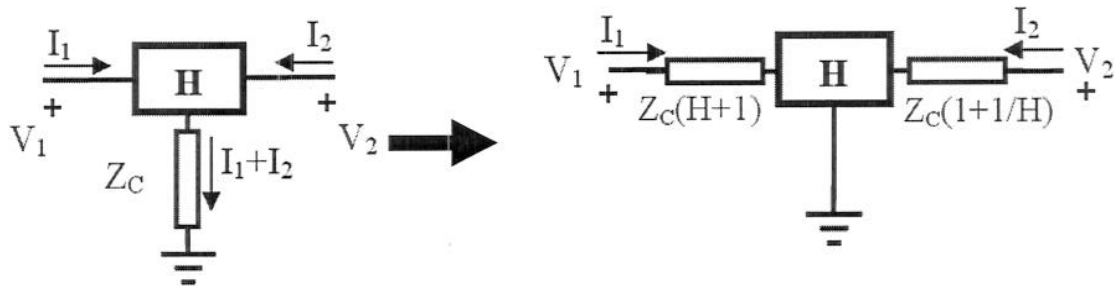

[4]

h)

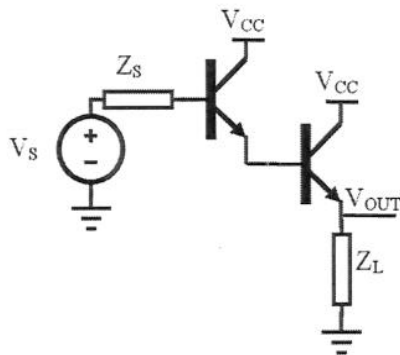

The darlington pair is a cascade of two emitter followers and behaves like a higher current gain emitter follower.

[4]

i) The gain bandwidth product of commercial op-amps is constant. At 1 MHz the gain is 10.

[4]

j)

$$f_T \approx \frac{1}{2\pi} \frac{g_m}{C_{BE}} = \frac{1}{2\pi} \frac{I_C}{V_T C_{BE}} \Rightarrow C_{BE} = \frac{1}{2\pi f_T} \frac{I_C}{V_T} = \frac{1}{2 \times 10^9} \frac{5 \times 10^{-3}}{25 \times 10^{-3}} = 10 \text{ nF}$$

[4]

Q2. [new problem, similar to problem in problem sheet and lab]

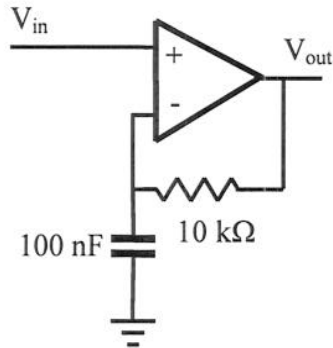

a)

$$v_- = v_{out} \frac{1}{1+sRC} \Rightarrow H(s) = (1+sRC)$$

$$RC = 1\text{m sec} = 159\text{Hz}$$

[5]

b)

$$v_- = v_{out} \frac{1}{1+sRC}$$

$$v_{out} = (v_+ - v_-) \frac{G_0}{1+s\tau} = \left(v_+ - v_{out} \frac{1}{1+sRC} \right) \frac{G_0}{1+s\tau} \Rightarrow$$

$$H(s) = \frac{v_{out}}{v_+} = \frac{G_0(1+sRC)}{(1+sRC)(1+s\tau) + G_0} =$$

$$= \frac{G_0}{1+G_0} \frac{1+sRC}{s^2\tau RC / (1+G_0) + (RC+\tau)s / (1+G_0) + 1} \approx \frac{1+sRC}{s^2\tau RC / (1+G_0) + (RC+\tau)s / (1+G_0) + 1}$$

This is the superposition of a low pass 2nd order filter:

$$H_{LP} = \frac{G_0}{1+G_0} \frac{1}{s^2\tau RC / (1+G_0) + s(RC+\tau) / (1+G_0) + 1} \approx \frac{1}{s^2\tau RC / (1+G_0) + s(RC+\tau) / (1+G_0) + 1}$$

and a band pass 2nd order filter:

$$H_{BP} = \frac{G_0}{1+G_0} \frac{sRC}{s^2\tau RC / (1+G_0) + (RC+\tau)s / (1+G_0) + 1} =$$

$$= \frac{G_0}{1+\tau/RC} \frac{s(RC+\tau) / (1+G_0)}{s^2\tau RC / (1+G_0) + s(RC+\tau) / (1+G_0) + 1}$$

Both have natural frequency and quality factor:

$$\omega_n = \sqrt{\frac{G_0+1}{\tau RC}}, \quad Q = \frac{1+G_0}{\tau+RC} \sqrt{\frac{\tau RC}{G_0+1}} = \frac{\sqrt{1+G_0}}{\sqrt{\sqrt{\frac{\tau}{RC}} + \sqrt{\frac{RC}{\tau}}}}$$

and gains $H_{0LP} = \frac{G_0}{1+G_0} \approx 1$, $H_{0BP} = \frac{G_0}{1+\tau/RC} \gg 1$

Clearly, the band pass character dominates.

[15]

c) This is a series-shunt connection.

If the feedback factor is $1+GH$, G being the forward and H the reverse gain, then

$$Z_{in} = Z_{in,OL} (1+GH), Z_{out} = Z_{out,OL} / (1+GH)$$

Once the transfer function is known the loop gain can easily be calculated:

$$G_{CL} = \frac{G_{OL}}{1+G_{OL}H} \Rightarrow$$

$$\frac{G_0}{1+G_0} \frac{1+sRC}{s^2\tau RC / (1+G_0) + (RC+\tau)s / (1+G_0) + 1} = \frac{G_0}{1+s\tau} \frac{1}{1+G_{OL}H} \Rightarrow$$

$$\frac{1}{1+G_{OL}H} = \frac{G_0}{1+G_0} \frac{1+sRC}{s^2\tau RC / (1+G_0) + (RC+\tau)s / (1+G_0) + 1} \frac{1+s\tau}{G_0} \Rightarrow$$

$$\frac{1}{1+G_{OL}H} = \frac{s^2\tau RC + (RC+\tau)s + 1}{s^2\tau RC + (RC+\tau)s + (1+G_0)}$$

$$\lim_{\omega \rightarrow 0} (1+GH) = G+1, \lim_{\omega \rightarrow \infty} (1+GH) = 1$$

[10]

Q3. [new computed example]

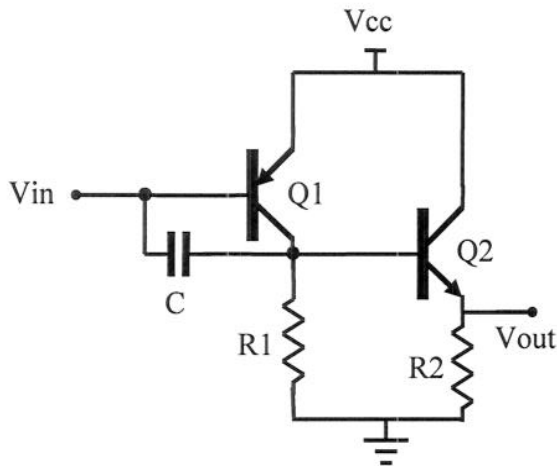

a) [bookwork and taught procedure]

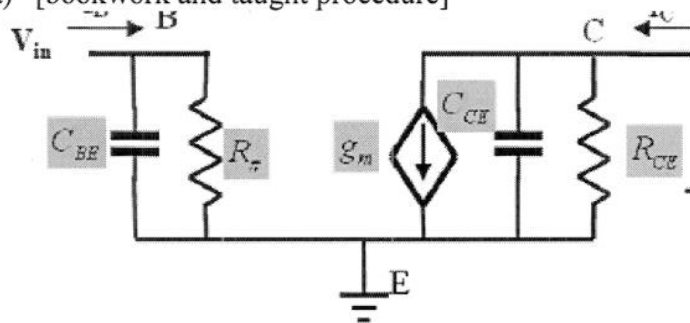

NPN :

$$g_m = \frac{i_c}{V_{th}} = \frac{.1mA}{25mV} = 4mS$$

$$f_T = \frac{g_m}{2\pi(C_{BE} + C_{BC})} \left. \begin{array}{l} \\ C_{BC} = C_{CE} = 0 \end{array} \right\} \Rightarrow f_T = \frac{g_m}{2\pi C_{BE}} \Rightarrow C_{BE} = \frac{g_m}{2\pi f_T} = \frac{4mS}{2\pi \cdot 500 \text{ MHz}} = 1.2pF$$

$$R_\pi = \beta / g_m = \frac{200}{0.004} = 50K\Omega, R_{CE} = \frac{V_A}{.1mA} = 1M\Omega$$

PNP :

$$g_m = \frac{i_c}{V_{th}} = \frac{.2mA}{25mV} = 8mS$$

$$f_T = \frac{g_m}{2\pi(C_{BE} + C_{BC})} \left. \begin{array}{l} \\ C_{BC} = C_{CE} = 0 \end{array} \right\} \Rightarrow f_T = \frac{g_m}{2\pi C_{BE}} \Rightarrow C_{BE} = \frac{g_m}{2\pi f_T} = \frac{8mS}{2\pi \cdot 100 \text{ MHz}} = 12pF$$

$$R_\pi = \beta / g_m = \frac{50}{0.008} = 6.25K\Omega, R_{CE} = \frac{V_A}{.2mA} = 250k\Omega$$

[10]

b) The input impedance of the second stage is $Z_{inNPN} = (\beta + 1)Z_E \approx 9G\Omega$ so it can be neglected in calculating the gain and input impedance of the first stage.

The low frequency first stage gain is $G_{1f \rightarrow 0} = -g_m R_1 = 25k\Omega \cdot 8mS = 200$

The second stage has a gain equal to $\lim_{f \rightarrow 0} G_2 = \lim_{f \rightarrow 0} \frac{g_m R_2}{1 + g_m R_2} = \frac{45k\Omega \cdot 4mS}{1 + 45k\Omega \cdot 4mS} = \frac{180}{181} \approx 1$

The overall gain is therefore 200.

[5]

c) By the Miller theorem, the input impedance is $Z_{in} = R_{\pi} // (1 + G)C$

[5]

d) The output impedance is $Z_{out} = (1 / g_m) // R_2 \approx 1 / g_m = 250\Omega$

[5]

e) The frequency response of the amplifier is dominated by the Miller decomposition of $C \gg C_{BE, NPN}$

The dominant pole is the lower frequency of the two time constants:

$\tau_{in} = (R_S // R_{\pi PNP})(1 + G)C$ and $\tau_2 = R_1 C$ at zero source impedance $\tau_{in} = 0$ so the dominant pole is at τ_2 . The two time constants are equal when

$$(R_{\pi PNP} // R_S)(1 + G)C = R_1 C \Rightarrow R_S \approx R_1 / G$$

Further increasing R_S undermines the amplifier bandwidth. for the numbers given this happens at $R_S \approx 125\Omega$

[5]

Q4) [synthesis of taught methods]

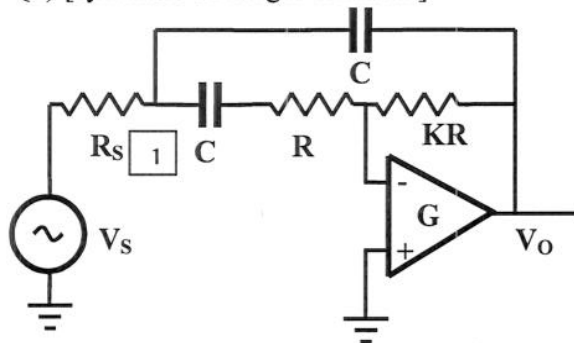

a) the circuit in the dashed lines is:

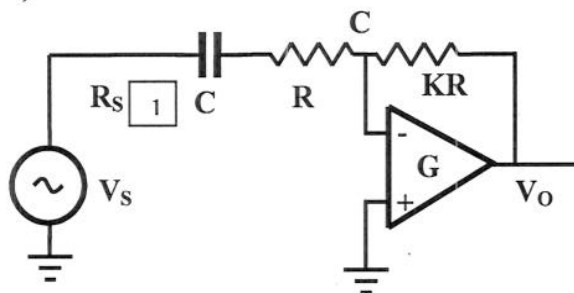

A model for this is

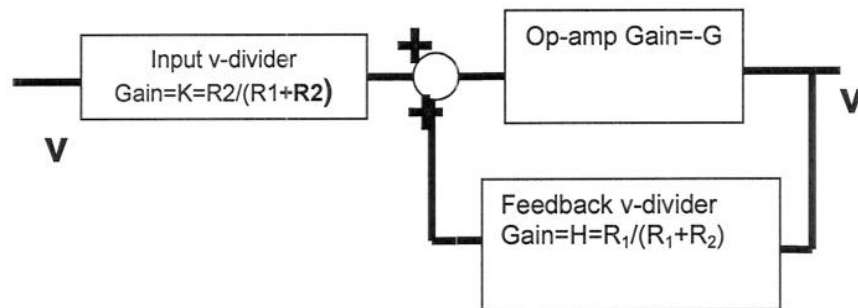

with $R_1 = \frac{1}{sC} + R, R_2 = KR$

[5]

b) the transfer function is (see notes):

$$H(s) = \frac{-KR s C}{(K+1)RsC+1} \frac{G}{1+G \frac{RsC+1}{(K+1)RsC+1}} = \frac{-GKs\tau}{(K+1+G)s\tau+(1+G)}$$

The input

impedance is $Z_{in} = \frac{1}{sC} + R + \frac{KR}{1+G}$ (from Miller Theorem)

[5]

c) The gain of this circuit is:

$$\begin{aligned}
 H(s) &= \frac{-Z_3 // Z_2}{Z_1 + (Z_3 // Z_2)} \frac{G}{1 + \frac{G(Z_1 // Z_3)}{Z_2 + (Z_1 // Z_3)}} = \\
 &= \frac{-Z_2 Z_3}{Z_1 Z_2 + Z_1 Z_3 + Z_2 Z_3} \frac{G}{1 + \frac{G Z_1 Z_3}{Z_1 Z_2 + Z_1 Z_3 + Z_2 Z_3}} = \frac{-G Z_2 Z_3}{Z_1 Z_2 + (1 + G) Z_1 Z_3 + Z_2 Z_3}
 \end{aligned}$$

The input impedance is:

$$Z'_{in} = Z_1 + Z_2 // Z_3 = \frac{Z_1 Z_2 + Z_1 Z_3 + Z_2 Z_3}{Z_2 + Z_3}$$

The block gains are

$$K = \frac{Z_2 // Z_3}{Z_1 + Z_2 // Z_3}, H = \frac{Z_1 // Z_3}{Z_2 + Z_1 // Z_3}$$

[10]

d) $Z_1 = \frac{1}{sC} + R, Z_2 = KR, Z_3 = Z_{nop-amp}, G(s) = G$

[5]

e) $Z_1 = R_s, Z_2 = Z'_{in}, Z_3 = 1/sC, G(s) = H(s)$

[5]