

IMPERIAL COLLEGE LONDON

DEPARTMENT OF ELECTRICAL AND ELECTRONIC ENGINEERING  
EXAMINATIONS 2010/2011

EEE PART II: MEng, BEng and ACGI

**ANALOGUE ELECTRONICS 2**

SAMPLE PAPER 1 (ISSUED DECEMBER 2010)

Time allowed: 2.00 hours

**There are THREE questions on this paper.**

**ALL questions are compulsory.**

**Question 1 carries 40% of the marks and Questions 2 and 3 carry 30% each.**

**Any special instructions for invigilators and information for candidates are on page 1.**

**Basic expressions for voltage gain, input and output resistance for single stage amplifiers are given on the last page.**

Examiners responsible	First Marker(s):	XXX
	Second Marker(s):	YYY

1. This question consists of 10 brief items. Each item can be answered in a few words or a short paragraph with use of a diagram and/or expression where helpful. Please answer all sub-questions, which carry equal marks.

- a) Explain what is meant by *source degeneration* in MOSFET amplifiers (or emitter degeneration) in BJT amplifiers. What are the advantages/disadvantages of using this technique? [4]
- b) Derive expressions (by inspection) for the voltage gain of the circuits shown below: [4]

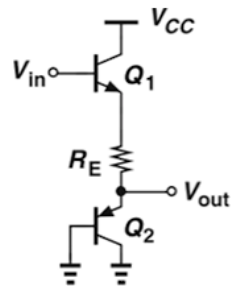

(i)

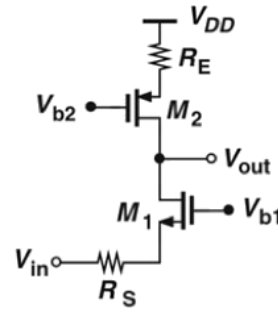

(ii)

- c) Explain the differences between *direct* and *capacitive coupling* and identify the related constraints when designing analogue integrated circuits. [4]
- d) With the aid of a diagram derive the expression for *Millers Theorem* applied to a capacitance. [4]
- e) State two benefits of using *negative feedback* in a system (over open-loop operation) and explain how the feedback achieves this. [4]
- f) Given two amplifier types (voltage and transconductance), which should have the lower output impedance? Explain your answer. [4]
- g) What is the *transit frequency*  $f_T$  of a transistor? Given the base-emitter capacitance of a BJT is 2.2pF, evaluate the transit frequency for a collector current of 5mA. [4]
- h) A commercial op-amp (LM741) is quoted an open-loop gain of approximately 106dB. What would be the gain error if configured in closed-loop as an inverting amplifier for a voltage gain of 250? [4]
- i) State two challenges in implementing voltage (or current) *bias generators* on-chip and briefly explain how each of these challenges may be overcome. [4]
- j) Explain how a *cascode stage* can be used to boost the voltage gain of an amplifier. What are the drawbacks of employing this technique? [4]

[Question 1 Total = 40]

2. A basic two stage operational amplifier is shown below:

This circuit consists of the differential pair ( $M_1$  and  $M_2$ ), an active current mirror ( $M_3$  and  $M_4$ ) to convert a differential to single-ended output, a second stage common source amplifier ( $M_5$ ), and biasing circuit ( $8k\Omega$  resistor and passive current mirror  $M_6-8$ ).

Assume all devices are in saturation and  $\lambda > 0$  (i.e.  $R_{out} < \infty$ ). Where required, use the following values:  $\mu_n C_{ox} = 200 \mu A/V^2$ ,  $\mu_p C_{ox} = 100 \mu A/V^2$ ,  $V_{TH,n} = 0.4V$ ,  $V_{TH,p} = -0.5V$ ,  $\lambda_n = 0.1V^{-1}$ ,  $\lambda_p = 0.2V^{-1}$ ,  $C_{GS} = (2/3)WLC_{ox}$ ,  $C_{ox} = 12fF/\mu m^2$ ,  $C_{DB} \approx 0$ ,  $C_{SB} \approx 0$  and  $C_{GD} = C_0W$ , where  $C_0 = 0.2fF/\mu m$  denotes the gate-drain capacitance per unit width.

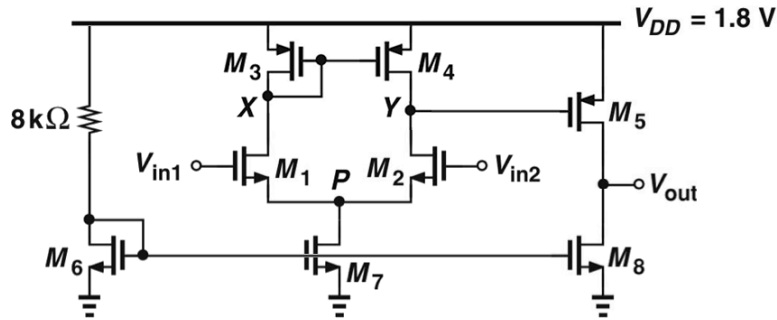

- Derive an expression for the differential voltage gain of the first stage ( $V_y/V_{in1}-V_{in2}$ ). [6]
- Derive an expression for the voltage gain of the second stage ( $V_{out}/V_y$ ) and therefore the total voltage gain ( $A_v=V_{out}/V_{in1}-V_{in2}$ ). [4]
- Given that:  $(W/L)_6=4/2$   
 $(W/L)_7=10/2$   
 $(W/L)_8=20/2$   
 Calculate the total power consumption of the circuit. [5]
- Given that:  $(W/L)_1=(W/L)_2=250/1$   
 $(W/L)_3=(W/L)_4=4/4$   
 $(W/L)_5=40/4$   
 Calculate the voltage gain (in dB). [5]
- Calculate the frequency of the pole associated with node  $Y$  ( $f_{pY}=\omega_{pY}/2\pi$ ) using Millers Theorem. [5]
- Calculate the frequency of the pole associated with the output node ( $f_{pout}=\omega_{pout}/2\pi$ ). Which is the dominant pole? [5]

[Question 2 Total = 30]

3. A “laser diode” converts current to light (as in laser pointers). It is required to design a circuit that delivers a well-defined current to a laser diode. In order to achieve this, negative feedback is applied to regulate the output bias. Two circuits that can achieve this are shown below: (i) with a common emitter output stage and (ii) with a common source output stage. In both these configuration, the resistor  $R_M$  measures the current flowing through  $D_1$  and amplifier  $A_1$  subtracts the resulting voltage drop from  $V_{in}$ .

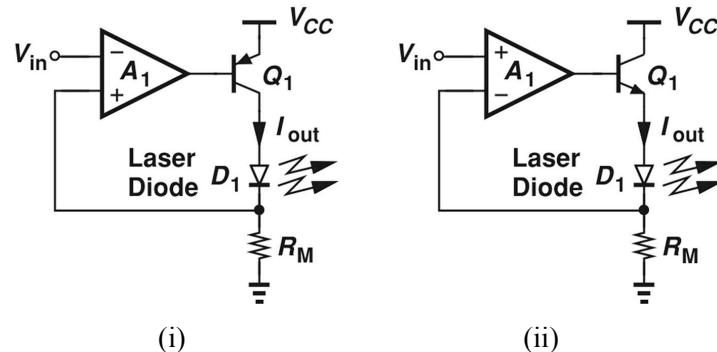

Assume  $R_M$  is very small and  $V_A = \infty$ .

- Explain how both circuits apply negative feedback even though the operational amplifier inputs are connected differently. [3]
- Considering the system as a whole (excluding only the laser diode), what type of amplifier is this? [2]
- Which topology is preferable? Explain your selection. [3]

Answer the remaining questions considering only circuit topology with the common emitter output stage, i.e. (i).

- Break the loop and determine the open-loop gain [5]
- Determine the feedback factor and loop gain [5]
- Derive an expression for the closed-loop gain [2]
- Derive an expression for the open-loop output impedance [3]
- Derive an expression for the closed-loop output impedance [2]
- Calculate the closed-loop gain and output impedance given  $A_1=100\text{dB}$ ,  $I_S=6 \times 10^{-16}\text{A}$  and  $R_M=10\Omega$ . [5]

[Question 3 Total = 30]

## Input and Output Impedances

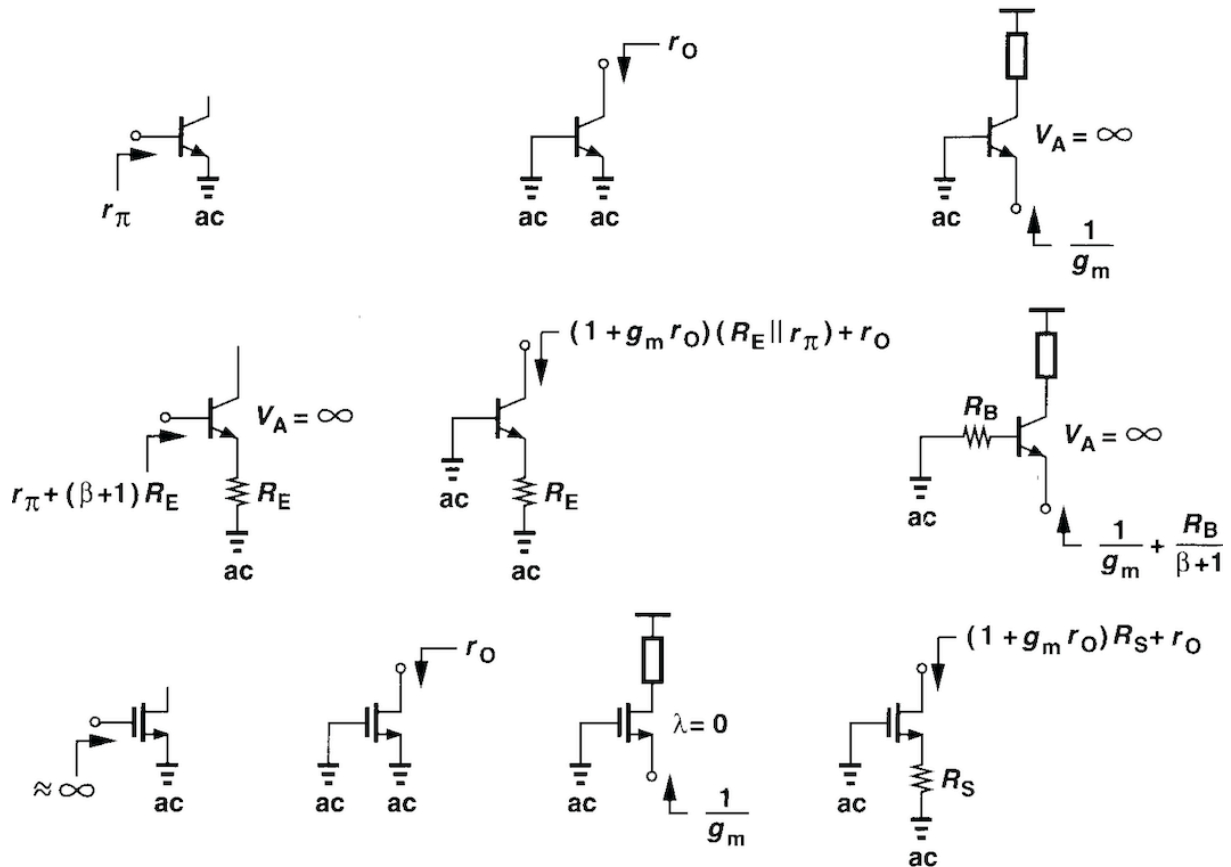

## Voltage Gain Equations

